



### SPECIFICATIONS

DN mm	DN50 - DN300
DN inch	2" - 12"
Temperature	0°C to 200°C
Type of body	Double flanges
Application	Clear water, Fire protection, Irrigation, Sewage
Flange	PN 10, PN 16
Valve Standard	EN 1171, EN 1074
Face to face	DIN 3202 F4
Flange drilling	EN 1092-2
Tightness test	EN 12266-1
Epoxy coating	150µm (standard), other thickness on request
Options	Other specifications on request

### ADVANTAGES

1. Excellent performance: low pressure drop and low torque
2. Full bore design
3. Wedge fully encapsulated in moulded EPDM
4. Linear sealing design provides better sealing and lower closing torque
5. Three independant stem seals offering triple safety: PTFE dust cover protects against dirt outside
6. A polyamid bearing with 3 NBR O-rings protects against galvanic corrosion
7. Operation: valve could be operated by hand wheel/head cap/worm gear/electric actuator

## DIMENSIONS

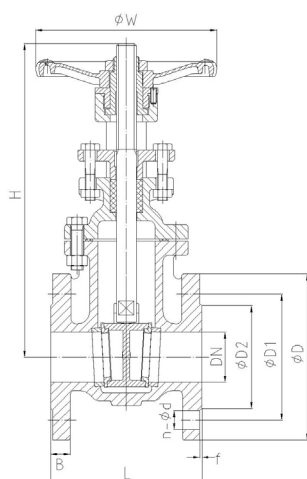

DN mm	DN inch	PFA	L	ØD	ØD1	ØD2	B	f	H	ØW	n-Ød
50	2"	16	150	165	125	99	19	3	369	180	4-Ø19
65		16	170	185	145	118	19	3	394	200	4-Ø19
80	3"	16	180	200	160	132	19	3	455	200	8-Ø19
100	4"	16	190	220	180	156	19	3	528	240	8-Ø19
125	5"	16	200	250	210	184	19	3	606	260	8-Ø19
150	6"	16	210	285	240	211	19	3	720	280	8-Ø23
200	8"	16 10	230	340	295	266	20	3	930	320	12-Ø23 8-Ø23
250	10"	16 10	250	405 395	355 350	319	22	3	1073	360	12-Ø28 12-Ø23
300	12"	16 10	270	460 445	410 400	370	25	4	1272	450	12-Ø28 12-Ø23

## NOMENCLATURE

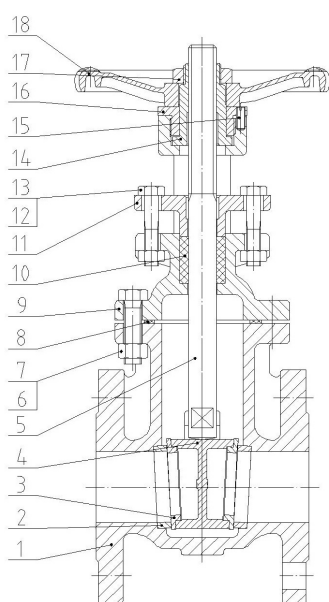

Designation	Materials
1.Body	Cast iron GG25 epoxy coated
2.Body sealing ring	Brass CuZn38Mn2Pb2
3.Disc sealing ring	Brass CuZn38Mn2Pb2
4.Disc	Cast iron GG25
5.Stem	Stainless steel 420
6.Bolt	Carbon steel
7.Nut	Carbon steel
8.Gasket	Carbon steel WCB + Graphite
9.Bonnet	Cast iron GG25
10.Packing	Graphite
11.Packing cap	Ductile iron GGG45
12.Bolt	Carbon steel
13.Nut	Carbon steel
14.Stem nut	Brass CuZn38Mn2Pb2
15.Screw	Steel
16.Pressing sleeve	Cast iron GG20
17.Nut	Steel
18.Handwheel	Ductile iron GGG45

