

Float valve balanced type Series J2 10

Balanced float valve with diaphragm actuated.



Descriptif

- Performances:
 - Balanced type valve,
 - Progressive operation without friction,
 - Low head loss.
- Design:
 - Compactness,
 - PEHD float,
 - Fully epoxy coated.
- No adjustment required.
- Maintenance-free.
- WRAS approved model on request.

Technical data

- Range: DN 40 to 250.
- Max working pressure: 10 bar.
- Max working temperature: +1° to 65° C.
- Flange drilling ISO PN 10 according to standards EN 1092-2 and ISO 7005-2 (ISO PN 16 for PN 16 execution for DN 200 and 250).

Options

- Ductile iron made.
- 316 L stainless steel float.
- Altitude setting.
- Bottom installation kit.
- PN 16.

Applications

- Control of top water level in reservoirs and storage tanks:
 - Drinking water networks.
 - Fire protection.
 - Irrigation.
 - High rise building.

Operation

A high resistance diaphragm balanced design with direct float and lever action compensates 90 % of the effect of the pressure on the main valve, with no risk of rubbing or sticking. Hence, the valves operating action is very smooth and only requires a relatively small float and mechanical parts.

The slight remaining pressure tending to open the valve (10 %), prevents vibrations and damps down the effects of rapid operations. The high lever-arm demultiplication factor results in the device being highly insensitive to oscillations on the water surface. The device is simple, robust, and requires no ajustement.

Item	Designation	Qty	Materials	Standards
1	Body	1	Cast iron/EN-GJL-250	EN 1561
2	Cover or bonnet	1	Cast iron/EN-GJL-250	EN 1561
3	Stem	1	Stainless steel 420F /X29CrS13	EN 10088
4	Diaphragm	1	Textile reinforced elastomer	
5	Sealing disk	1	Polyurethane/PUR	
6	Link	1	Galvanized steel/S235-JR	EN 10025
7	Lower lever	1	Galvanized cast/EN-GJMB-350-10	EN 1562
8	Float lever	2	Galvanized steel /S235-JR	EN 10025
9	Pin split pin	2	Stainless steel 304L/X2CrNi 18-09	EN 10088
10	Pin split pin	1	Stainless steel 304L/X2CrNi 18-09	EN 10088
11	Pin split pin washers	2	Stainless steel 304L/X2CrNi 18-09	EN 10088
12	Float	1	PEHD	
13	Threaded insert	1	Stainless steel 316L/X2CrNiMo17-12-2	EN 10088
14	Bolts	s/DN	Steel with anticorrosion coating	

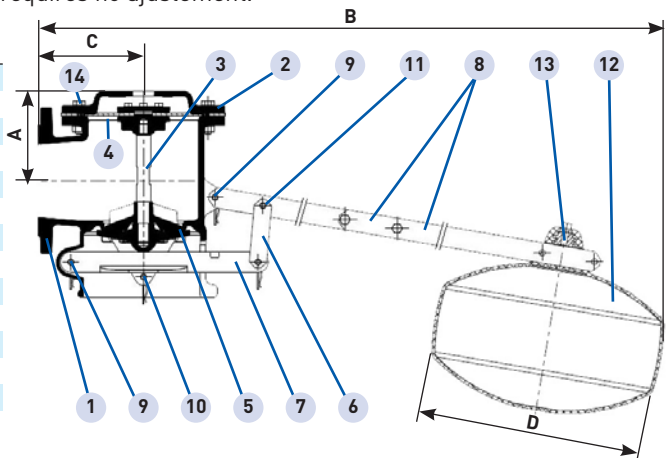

DN	A mm	B mm	C mm	D mm	H mm	H' mm	E mm	Weight kg
40	108	1490	115	380	250	950	190	21
50	108	1490	115	380	250	950	190	22
60	108	1490	115	380	250	950	190	22
65	108	1490	115	380	250	950	190	23
80*	128	1550	150	380	270	1050	210	30
100	128	1550	150	380	270	1050	210	31
125	159	2020	180	435	350	1200	230	48
150	159	2020	180	435	350	1200	230	51
200	230	2310	270	435	400	1500	285	126
250	230	2310	270	435	400	1500	285	130

* DN 80 drilling 4 or 8 holes

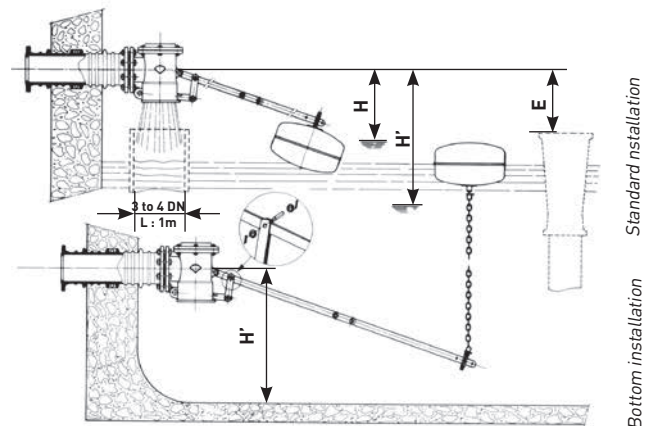

Mounting

Check that the emplacement provided for in the wall of the reservoir coincides with the table (especially with respect to distance E, for which only a tolerance of ± 20 mm should be allowed).

Before positioning the device, thoroughly flush the pipeline. The lever arm and float are delivered in kit-form.

For installation at the bottom of the reservoir, use the complementary kit consisting of: a 4 m stainless steel chain, two attaching clamps and two hook pieces.

Distance H' (lever-arm swing) must be respected.

If the working pressure is greater than 1 bar, we strongly recommend the installation of a stilling well (PVC, steel, iron, concrete, asbestos) as shown in figure below.

The function of this tube is to eliminate too great a disturbance of the water-surface upon closing the valve.

Recommended flow rate / sizing

Two cases to choose the diameter according to the flow rate:

- When inlet pressure is low (≤ 1 bar) we recommend to size the float valve according to case 1. Head loss in the fully open valve will be about 2 m WC.
- When inlet pressure is high, float valves be sized according to case 2. Head loss will be about 5 m WC.

There is a progressive variation in flow rate with respect to the water-level, from the point where the device is fully open (H') to the valve being closed (H) (see Mounting figure).

Flow rates in l/s

DN	40	50	60/65	80	100	125	150	200	250
Case 1	2	3	4	7.5	12	18.5	26.5	47	74
Case 2	3	5	7	12.5	20	31	44	78.5	123

Altitude setting option

Only for DN 40 to 100, 25 mm step setting.

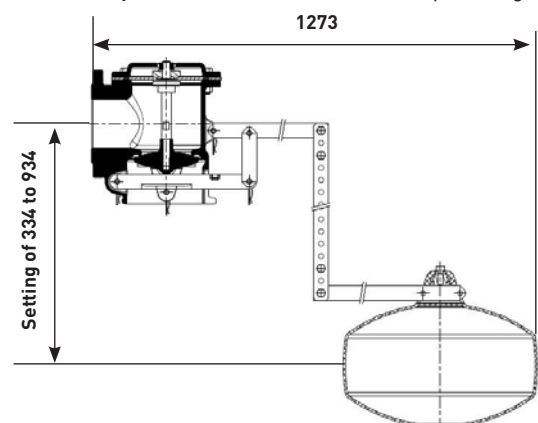

The technical data and performance can be modified without prior notice depending on the technical evolution.