

SPECIFICATIONS

DN mm	DN40 - DN300
DN inch	1"1/2 - 12"
Temperature	EPDM -10°C to 120°C
Type of body	Wafer
Application	Water, General industry, Production processes, Hydrocarbons
Flange	PN 25
Options	Other specifications on request

ADVANTAGES

1. Compact design and space saving
2. Vulcanized seal on the valve seat to ensure water tightness
3. Excellent hydraulic performance
4. Little energy loss
5. The stainless steel spring pushes against the two plates, to maintain pressure on the valve seat seal
6. Gradual opening controlled by double contact spring
7. Horizontal or Vertical installation, facing upward

DIMENSIONS

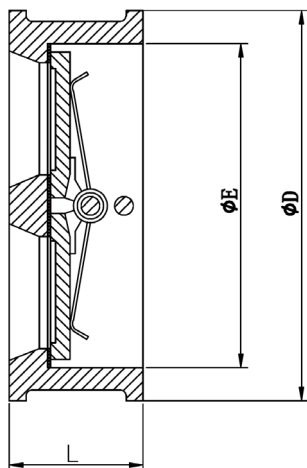

DN mm	DN inch	PFA	L	øE	øD
40	1"1/2	25	43	65	92
50	2"	25	43	65	107
65	2"1/2	25	46	80	127
80	3"	25	64	94	142
100	4"	25	64	117	162
125	5"	25	70	145	192
150	6"	25	76	170	218
200	8"	25	89	224	273
250	10"	25	114	265	329
300	12"	25	114	312	384

NOMENCLATURE

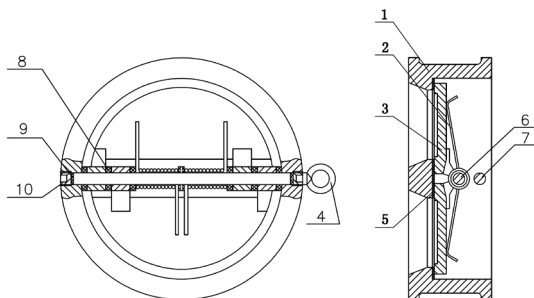

Designation	Materials
1.Body	Ductile Iron epoxy coated
2.Spring	Stainless Steel
3.Disc	Aluminium-Bronze
4.Ring	Steel
5.Seat	EPDM
6.Shaft	Stainless Steel 304
7.Shaft	Stainless Steel 304
8.Gasket	PTFE
9.Gasket	NBR
10.Stub screw	Steel

HEADLOSS

