

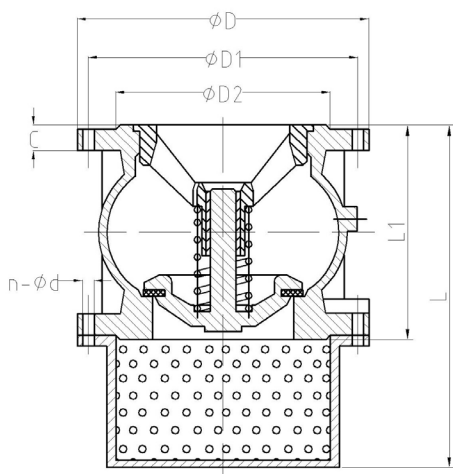

## DIMENSIONS



DN mm	DN inch	PFA	$\phi D$	$\phi D1$	$\phi D2$	C	L1	L	n- $\phi d$
50	2"	16	165	125	99	17	100	177	4- $\phi 19$
65	2 1/2"	16	185	145	118	17	120	217	4- $\phi 19$
80	3"	16	200	160	132	19	140	257	8- $\phi 19$
100	4"	16	220	180	156	21	170	315	8- $\phi 19$
125	5"	16	250	210	184	23	200	367	8- $\phi 19$
150	6"	16	285	240	211	23	230	427	8- $\phi 23$
200	8"	16 10	340	295	266	27	301	548	12- $\phi 23$ 8- $\phi 23$
250	10"	16 10	405	355	319	29	370	667	12- $\phi 28$ 12- $\phi 23$
300	12"	16 10	460	410	370	29	410	757	12- $\phi 28$ 12- $\phi 23$

## NOMENCLATURE

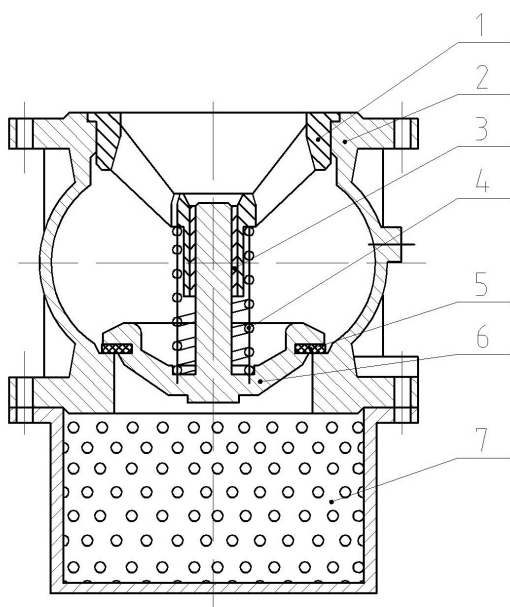

Designation	Materials
1. Guide	Ductile iron GGG40
2. Body	Cast iron GG25
3. Guide sleeve	PTFE
4. Spring	Stainless Steel 316
5. Seal gasket	EPDM
6. Disc	Ductile iron GGG40
7. Strainer	WCB

## HEADLOSS

