

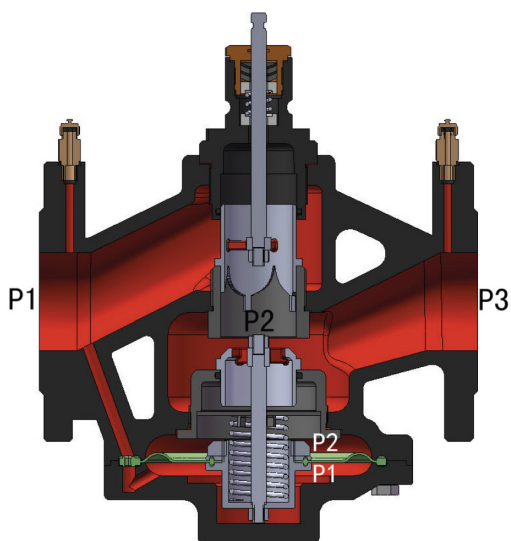

SPECIFICATIONS

DN mm	DDN32 - DN250
DN inch	1"1/4 - 10"
Temperature	-10°C to 120°C
Type of body	Flanges
Application	Cold/hot water, Glycol solution concentration < 50%
Connection	Flanged ISO 7005-2 PN16
Test	EN 12266-2 (Test body safety and tightness, Test seat tightness)
options	Other specifications on request

ADVANTAGES



• High Control Precision

Both the electric valve core and balancing valve core adopt straight travel design. Compared with rotary design, straight travel has higher control precision.

• High Close Off DP, Low Leakage

The valve has a higher close off differential pressure, while the leakage is lower than 0.02% of KVS.

• Build-in Diaphragm Capsule and Connecting Pipe

The valve adopts the build-in diaphragm capsule and connecting pipe. It can avoid damaging during installation compared with external connecting pipe.

• Anti-blocking Design

The balance structure of spring diaphragm significantly reduces the probability of blocking in valve body. Because of the lower requirement for water quality, it can easily deal with the water in heating pipeline.



• High-quality Material

The valve body is made of high-quality ductile iron material (QT450-10), and the surface adopts electrostatic spraying craft, the valve stem and valve core are made of high-quality stainless steel.

TYPE SUMMARY

PICV for AHU

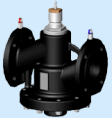
Series	TW1000...	TW1001...	TW3000...
Actuator Rated Stroke	30mm	50mm	50mm
Nominal Output Force	1000N	1000N	3000N
Icon			
Proportional type 0(2)~10VDC,0(4)~20mA	TW1000-XD24-S.12	TW1001-XD24-S.14	TW3000-XD24-S.14
3-position type(on/off)	TW1000-XD24-S.12	TW1001-XD24-S.14	TW3000-XD24-S.14
RS485 bus and NFC(optional)	TW1000-XD24-S485.12	TW1001-XD24-S485.14	TW3000-XD24-S485.14
2 SPDT Feedback Function(optional)	TW1000-XD24-SF2.12	TW1001-XD24-SF2.14	TW3000-XD24-SF2.14

Valve Body	Type	DN [mm]	Stroke [mm]	Qmax [m³/h]	ΔP_s [MPa]	ΔP_s [MPa]	ΔP_s [MPa]
PN16 . Medium Temp. . -10 °C ~ 120°C 	Flanged	TPF32-2VGC-S.12	DN32	20	7	0.40	
		TPF40-2VGC-S.12	DN40	20	11	0.40	
		TPF50-2VGC-S.12	DN50	20	13	0.40	
		TPF65-2VGC-S.12	DN65	20	21	0.40	
		TPF80-2VGC-S.14	DN80	40	28		0.40
		TPF100-2VGC-S.14	DN100	40	50		0.40
		TPF125-2VGC-S.14	DN125	40	90		0.40
		TPF150-2VGC-S.14	DN150	40	145		0.40
		TPF200-2VGC-S.14	DN200	40	208		
TPF250-2VGC-S.14	DN250	40	240			0.40	
PN25 . Medium Temp. . -10 °C ~ 120°C 	Flanged	TPF32-2VGD-S.12	DN32	20	7	0.40	
		TPF40-2VGD-S.12	DN40	20	11	0.40	
		TPF50-2VGD-S.12	DN50	20	13	0.40	
		TPF65-2VGD-S.12	DN65	20	21	0.40	
		TPF80-2VGD-S.14	DN80	40	28		0.40
		TPF100-2VGD-S.14	DN100	40	50		0.40
		TPF125-2VGD-S.14	DN125	40	90		0.40
		TPF150-2VGD-S.14	DN150	40	145		0.40
		TPF200-2VGD-S.14	DN200	40	208		
TPF250-2VGD-S.14	DN250	40	240			0.40	

FLOW CHARACTERISTIC

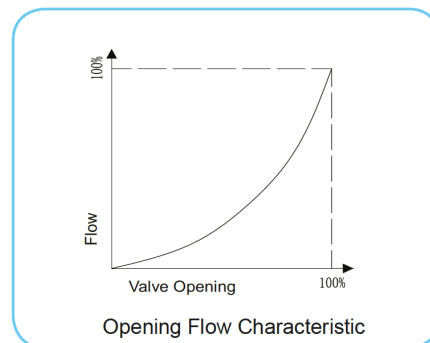
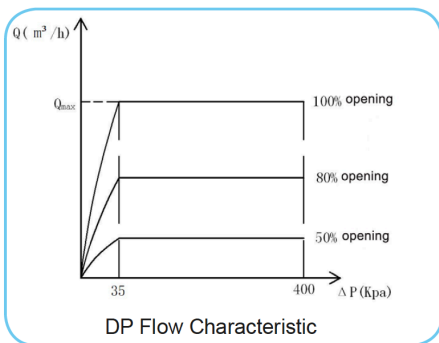

DN (mm)	Opening (%) - Flow (m³/h)														
	30	35	40	45	50	55	60	65	70	75	80	85	90	95	100
50	1.4	1.9	2.19	2.74	3.18	3.93	4.6	5.5	6.24	7.25	8.35	9.68	11	12.1	13
65	2.55	3.41	4.15	5.26	6.33	7.12	8.9	10.3	11.9	13.4	14.9	16.3	17.6	19.3	21
80	2.76	3.62	4.48	5.57	6.79	7.62	9.33	10.8	12.3	13.9	15.7	17.4	18.9	23.6	28
100	7.91	9.85	11.6	15.7	18.8	21.5	23.8	25.7	27.6	29.4	33.1	38	42.9	46	50
125	8.4	10.5	12.5	16	19.3	24.5	29.8	37.5	46.3	55.6	65.1	72.3	80	84.5	90
150	17	28	41	55	69	80	94	102	112	116	120	124	129	135	145
200	35	43	51	61	71	79	86	96	107	124	140	155	170	190	208
250	42	48	59	65	78	90	101	113	131	150	179	197	216	228	240



DIMENSION FIGURE

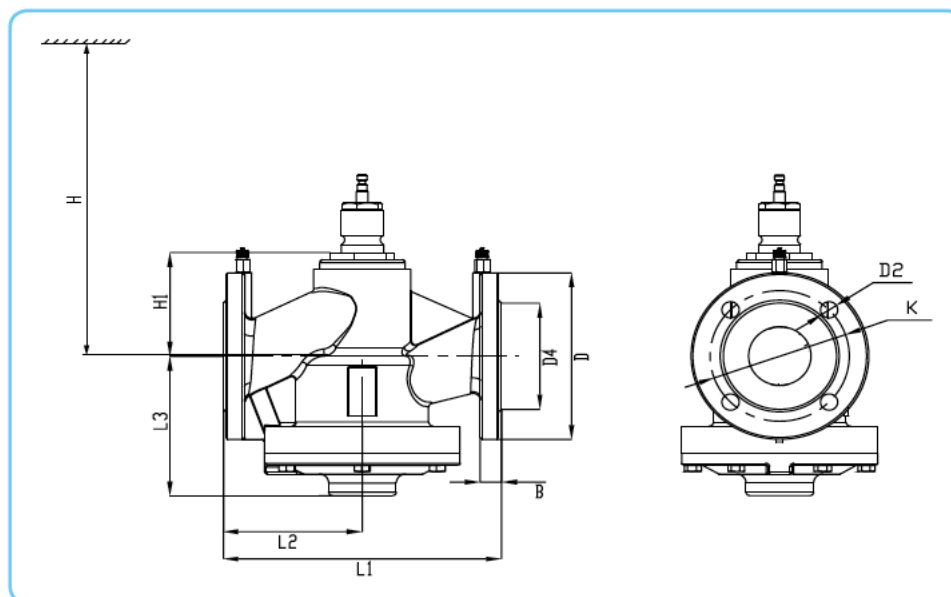

PN16											
DN	B mm	D mm	D2 mm	D4 mm	K mm	L1 mm	L2 mm	L3 mm	H1 mm	H mm	Weight kg
32	18	140	4-19	76	100	180	90	130	84	399	15
40	18	150	4-19	84	110	200	100	131	89	404	17
50	20	165	4-19	99	125	230	115	136	95	410	19
65	22	185	4-19	118	145	290	145	155	115	430	28
80	24	200	8-19	132	160	310	155	167	148	483	36
100	22	220	8-19	156	180	350	181	181	150	485	54
125	26	250	8-19	184	210	400	200	197	163	498	68
150	24	285	8-23	211	240	480	240	222	198	533	89
200	24	340	12-23	266	295	500	250	245	180	525	140
250	26	405	12-28	319	355	600	300	277	210	555	207

PN25											
DN	B mm	D mm	D2 mm	D4 mm	K mm	L1 mm	L2 mm	L3 mm	H1 mm	H mm	Weight kg
32	18	140	4-19	76	100	180	90	130	84	399	16
40	18	150	4-19	84	110	200	100	131	89	404	18
50	20	165	4-19	99	125	230	115	136	95	410	21
65	22	185	8-19	118	145	290	145	155	115	430	30
80	24	200	8-19	132	160	310	155	167	148	483	38
100	22	235	8-23	156	190	350	181	181	150	485	57
125	26	270	8-28	184	220	400	200	197	163	498	73
150	24	300	8-28	211	250	480	240	222	198	533	94
200	24	360	12-28	274	310	500	250	245	180	525	145
250	26	425	12-31	330	370	600	300	277	210	555	216



INSTALLATION INSTRUCTION

1. When the valve is connected with pipeline, if the medium is chilled/hot water, downward installation is forbidden.



Note:
The medium flow direction in valve should be consistent with the medium of pipeline!

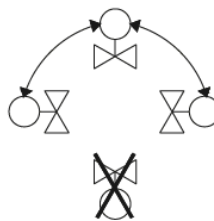

2. As shown in the right figure, when valve is installed, tighten the bolts and nuts diagonally.

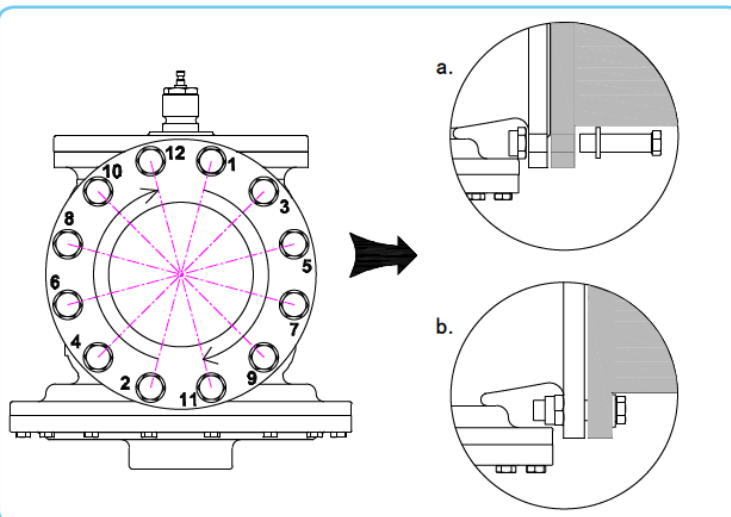

Note:



As shown on the right, the flange holes for DN200 must use the equipped 4 sets of bolt, washer and nut!

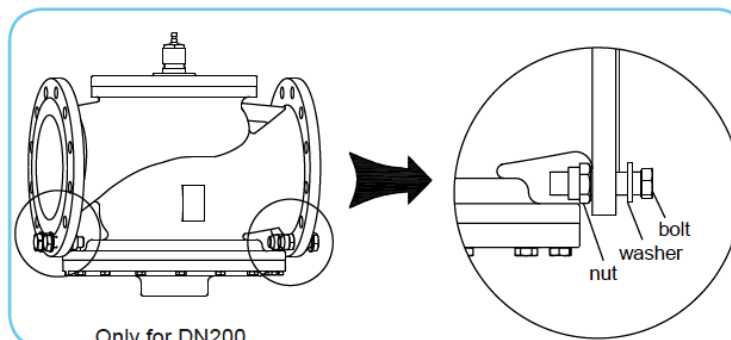

Only for DN200

3. Valve and actuator can be assembled easily. Neither need any special tools, nor need to do any adjustment.



Note:
The two connecting faces of valve stem and actuator shaft should keep coinciding!



Note:
When we do the pipe water pressure testing, the valve should be in the state of full open! If not, the internal diaphragm of valve body will be damaged and lose the balancing function!



Note:
1. Prohibit installing outdoor to avoid PCB damage due to the condensation and water
2. Rain cover and heating belt are necessary in case install outdoor.

1 Take down the fixed fitting, and disentangle the clip, prepare for assembling actuator.

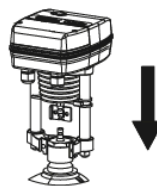

2 Make sure the actuator shaft is concentric with the valve stem (which can be observed from the hole), and make these two connecting faces keep coinciding. Then tighten the two screws on the clip.

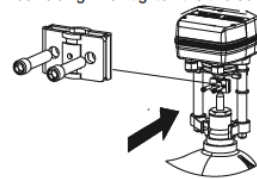

3 Pull the fixed fitting to the groove and lock it by two screws.

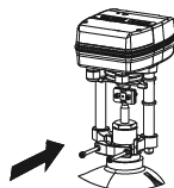

4 This is how the valve and actuator should look after correct assembly.

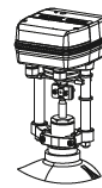

Item	Model	Actuator rating force	Heating Belt Power	Recommended transformer power	Recommended Power Supply	Description
Heating belt	THOT-3	600N-1000N	4VA	60VA	30VA	To prevent condensation inside, the heating belt is built-in before delivery
		3000/5000	5VA	80VA /100VA	50VA /60VA	
Rain cover	TRAIN-1	/	/	/	/	To prevent the actuator from rain



Omeax SARL, 27 avenue Monnot Prolongée, F-71100 Chalon-sur-Saone, FRANCE.

contact@omeax.com <http://www.omeax.com>

Omeax is not responsible for any possible errors in catalogue, brochures and on website.

This datasheet is subject to change without notice. All right reserved.



Notes:

1. Open the cover when wiring, prohibit disassembling other spare parts!
2. Carefully check the power voltage when wiring, wire according to the product parameters, otherwise, it may cause fire and endanger personal safety in severe case!
3. Please cut off power supply during wiring to ensure personal safety!
4. After wiring, please install the cover to the original position to avoid the danger of electric shock caused by exposed terminal!

1. Open the cover and prepare to wire.

2. Wire correctly according to the wiring diagram.

a. 24V Terminal Diagram

b. 220V Terminal Diagram

WIRING DIAGRAM

- TW...-XD24..wiring diagram

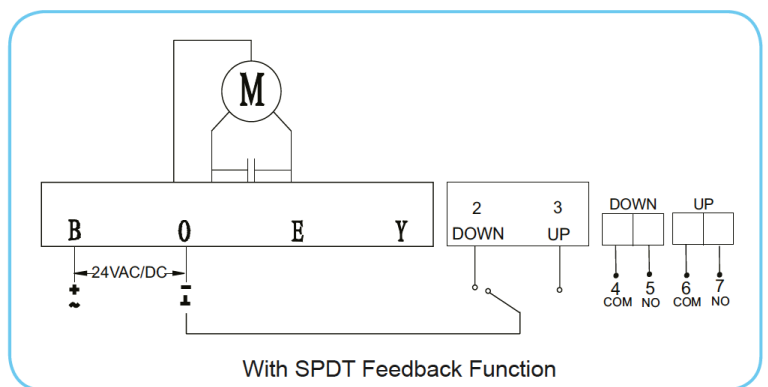
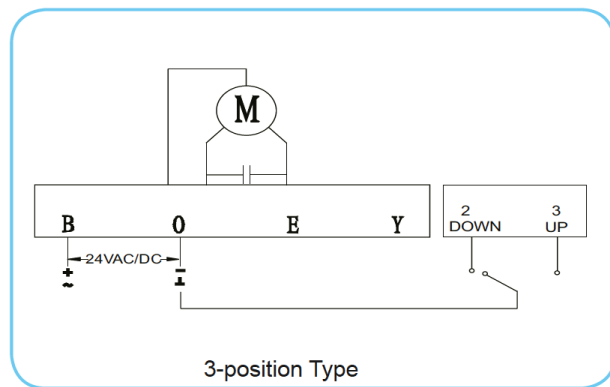
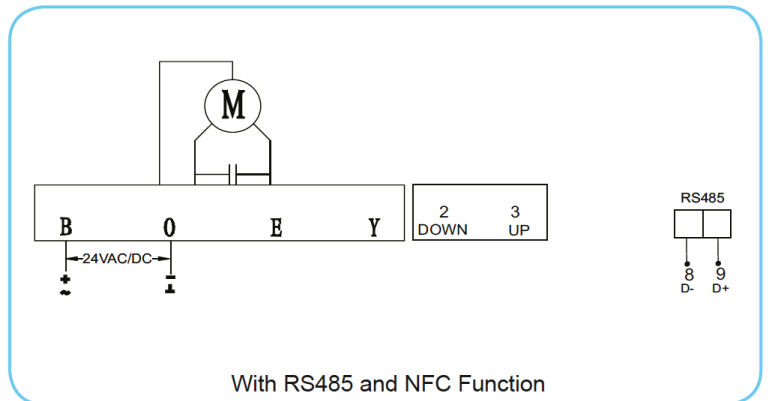
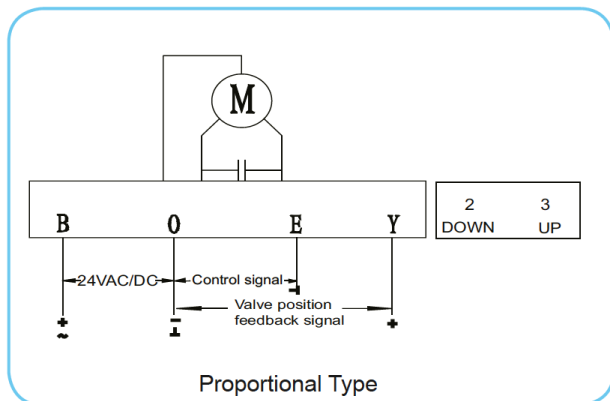

• TW...-XD220...wiring diagram

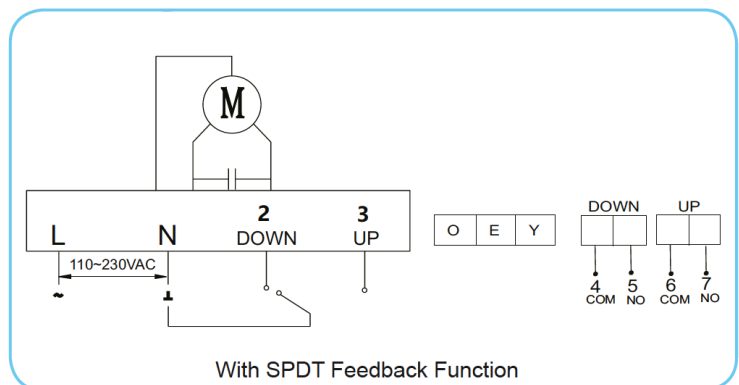
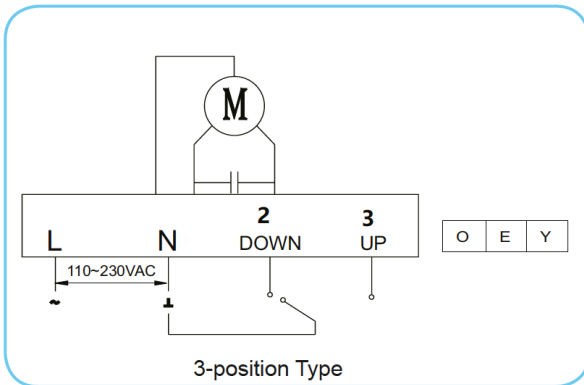
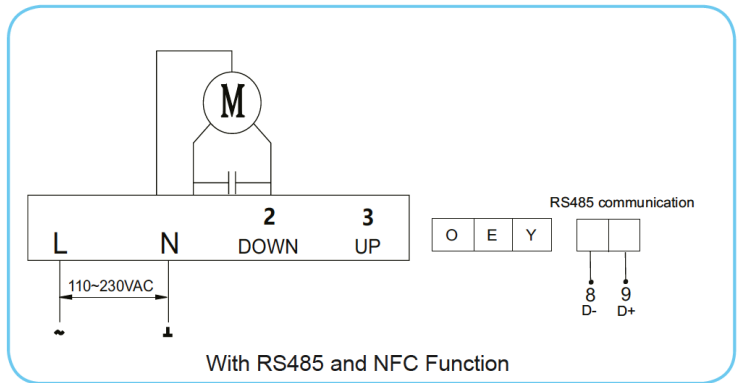
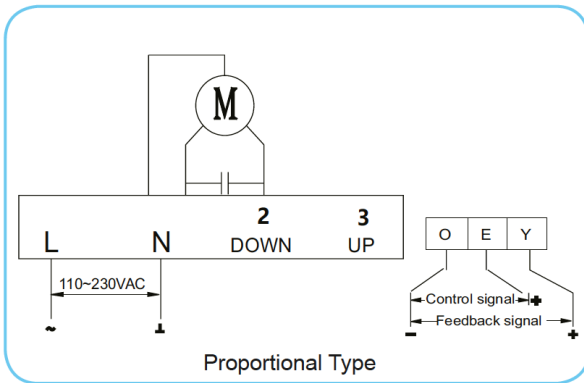

Note:

Please confirm the power voltage before wiring! The wrong power connection may cause permanent circuit board damage, serious may cause fire and endanger personal safety!

INDICATING LIGHT

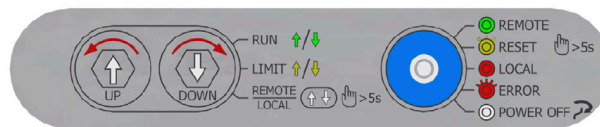

• Reset Light

Reset	Status	Description
Green	Always	Normal mode
Red	Always	Local mode
Yellow	Flashing (1Hz)	Self-stroking
Red	Quick flashing (2Hz)	Alarming

• Retractive Light-UP

UP	Status	Description
Green	Always	Normal mode
Yellow	Always	Reach upper limit position
Red	Flashing (1Hz)	Alarming
Red	Always	Local mode

• Extended Light-DOWN

DOWN	Status	Description
Green	Always	Normal mode
Yellow	Always	Reach lower limit position
Red	Flashing (1Hz)	Alarming
Red	Always	Local mode



DEBUGGING INSTRUCTION

- A. Connect actuator and valve body.
- B. Connect the power supply and the control signal line.
- C. Set DIP Switch to needed position. After setting, turn on the actuator power, pre-setting function will come into effect. (DIP Switch can be set with power)
- D. Power on the actuator.
- E. Actuator self-stroking: the purpose of this step is to match the actuator with the valve body:
- 1) The actuator Reset yellow light flashes (1Hz), actuator runs to lower limit position firstly, then runs to upper limit position, actuator will not controlled by control signal by this time.
 - 2) After 3 mins, Reset yellow light stops flashing, self-stroking stops and the matching of the valve and actuator is finished. By then, actuator running direction can be controlled by control signal.
 - 3) If the Reset red light is quick flashing (2Hz) during the self-stroking, it means the self-stroking status is not correct and the actuator starts alarming. The actuator can't match with the max. stroke of valve.
- Remarks: If self-stroking is needed in a power-on state, press down the Reset button over 5s, and then the actuator will start self-stroking. Self-stroking phenomenon is the same as step 1), 2).
- F. Local mode: press the button UP, DOWN at the same time over 5s, loosen the buttons and the actuator starts the local mode. At this time, the UP, DOWN and Reset lights are in red. If you need actuator shaft retracts, long press the button UP and the UP light will always be on green; If you need actuator shaft extends, long press the button DOWN and it always be on green. After it reaches to the expected position, repress UP, DOWN at the same over 5s and then it will exit the local mode.

Notes:

1. The factory default setting is automatic self-stroking, it means the actuator will repeat automatic self-stroking when power on each time!
2. If you don't need automatic self-stroking function, you can set the 7th switch to OFF, it will change into manual self-stroking (Phenomenon is the same as step 1), 2).

FUNCTION INTRODUCTION

Proportional Type
Control signal/feedback signal: 0~10VDC

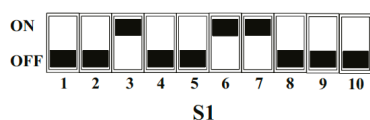

As shown in the left, when equipped with Pressure Independent Control Valve, DIP Switch S1-5 is DA mode:

Control signal at terminal O,E increasing: actuator shaft retracts, valve stem extends, valve tends to open.

Control signal at terminal O,E decreasing, actuator shaft extends, valve stem retracts, valve tends to close.

Control signal at terminal O,E has no changing, actuator shaft and valve stem stay in present position.

When voltage (or current) signal is disconnected, this is equivalent to input the min. control signal, actuator shaft retracts, valve closed.

DIP SWITCH INSTRUCTION

Switch	Function	Description
S1-1	Starting of control/feedback signal	ON 20%:the starting of control/feedback signal is 20%(namely 4~20mA or 0~10VDC)
		OFF 0:the starting of control/feedback signal is 0(namely 0~20mA or 0~10VDC)
S1-2	Type of control signal	ON II:current signal
		OFF UI:voltage signal
S1-3	Impedence match of control signal	ON UI:voltage signal
		OFF II:current signal
S1-4	Type of feedback signal	ON IO:current signal
		OFF UO:voltage signal
S1-5	Operating mode	ON DA:When the control signal increase, actuator shaft extends;When the control signal decrease, actuator shaft retracts.
		OFF RA:When the control signal increase, actuator shaft retracts;When the control signal decrease, actuator shaft extends.
S1-6	Losing control signal mode	ON DW:When lose control signal (voltage type or current type), actuator will provide a min. control signal internally.
		OFF UP: 1)When lose control signal (voltage type),actuator will provide a max. control signal internally. 2)When lose control signal (current type),actuator will provide a min. control signal internally.
S1-7	Self-stroking mode	ON DF:Power on each time, self-stroking starts automatically.
		OFF RF:Self-stroking starts only when press the red self-stroking button manually.
S1-8	Control mode (when S1-9 is OFF)	ON 3-position type
		OFF Proportional type
S1-9	Control type	ON RS485 interface control(Modbus protocol)
		OFF Proportional type and 3-position type
S1-10	Speed	ON TW500/1000/1001/3000 High speed:1s/mm
		OFF TW500/1000/1001/3000 Medium speed:2s/mm



• Operating Parameters

Caliber Range	DN32~DN250
Permissible Pressure	PN16, PN25 are optional
Connection Standard	Flanged connection ISO7005-2
Medium Temperature	-10~120°C
Permissible Medium	Chilled/hot water, glycol under 50%
Operating Voltage	
TW...-XD24...	24VAC± 15%, 24VDC+ 15%
TW...-XD220...	110~230VAC,+10...-15%
Frequency	50Hz / 60Hz
Power Consumption	
TW500/1000/1001-XD24...	Run: 14VA; Max.: 25 VA
TW3000-XD24...	Run: 23VA; Max.: 35 VA
TW500/1000/1001-XD220...	Run: 10VA; Max.: 20 VA
TW3000-XD220...	Run: 19VA; Max.: 35 VA
Speed	
TW500/1000/1001/3000...	High speed:1s/mm; Medium speed: 2s/mm
Sensitivity (can be adjusted between 0.2%~10% by NFC mobile software)	Proportional type: 0.8% (factory setting) RS485: 0.2% (factory setting)
Dead Zone(Can be adjusted between 1%~10% by NFC mobile software)	2%(factory setting)
Impedance (only for proportional type)	
Voltage Input Impedance	> 100K
Current Input Impedance	<0.125K
Load Requirements (only for proportional type)	
Voltage Output Load Requirement	> 1K
Current Output Load Requirement	<0.5K
Control Signal	
TW...-BX...	0(2)~10VDC, 0(4)~20mA
TW...-BX...-485	RS485
Valve Position Feedback Signal	
TW...-BX...	0(2)~10VDC, 0(4)~20mA
TW...-BX...-F2	2 SPDT feedback
TW...-BX...-485	RS485
Protection Level	IP65

*Remark: when medium temperature in valve is below 0°C, such as:refrigerant (R12,R22,R134a,R202), glycol and so on, valve stem should be protected by stem heater (Type:THOT...) to avoid the connection parts of valve body and valve stem frosting and icing.

• Spare Parts Material

Valve Body	Ductile iron QT450-10
Valve Core	Stainless steel
Valve Stem	Stainless steel
Sealing Ring	PTFE
Diaphragm	EPDM
Cover	PC
Bracket	Stainless steel
Base	Aluminum die casting

