





## Product advantage

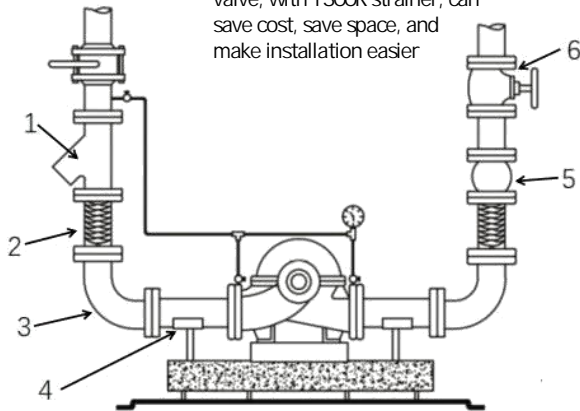

Fig.T300R

Compared with the traditional pipe, using our multifunctional valve, with T300R strainer, can save cost, save space, and make installation easier



Fig.KS100R



Conventional pipe

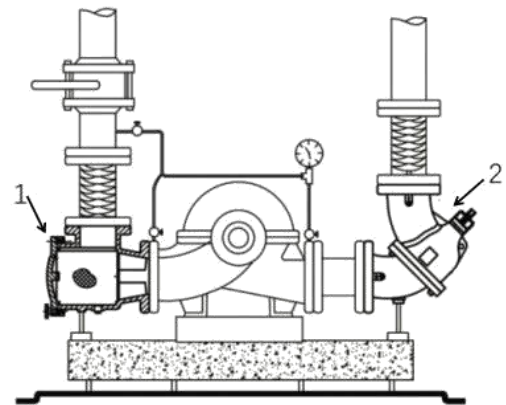

The use of KS100R multifunctional valve and T300R deflector pipe

1. "Y" Strainer
2. Flexible connectors
3. Radius elbow
4. Suction pool piece
5. Discharge check valve
6. Discharge globe valve

1. Fig.T300R, T type Strainer
2. Fig.KS100R, multi-function valve



Omeax is not responsible for any possible errors in catalogue, brochures and on website. This datasheet is subject to change without notice. All right reserved.