

# OMEAX

## OMEAX

OMEAX – France :  
1 rue Dewet  
F-71100 Chalon-sur-Saone  
FRANCE  
Tel: +33 385 970 981  
<https://omeax.com/>  
[contact@omeax.com](mailto:contact@omeax.com)



## EMT / EMD Series

Multi-turn Electric Actuator

Subject to change without notice.  
Reproduction of part or all of the contents of this manual is prohibited.  
Under the copyright laws, the contents of this product manual are forbidden  
for any other purpose without the permission of Omeax corporation.

VER:EN-FF202306-V01



# CONTENT

◆ Product Overview .....	01
◆ Product Features .....	02
◆ EMT series .....	03-12
◆ EMD series .....	13-23
◆ Service .....	24

Product Overview

The multi-turn electric actuator is an actuator with an output angle greater than 360°. It is suitable for valves with multi-turn stroke for linear travel, such as gate valves, globe valves, regulating valves and others. It can also be paired with 90° gearbox to achieve quarter turn travel for valves such as butterfly valves, ball valves, plug valves and others.

Omeax multi-turn electric actuators come with two series: EMT and EMD. Depend on different application the two series can be applied selectively. These two series of products are divided into three types: basic type, integration type and intelligent type according to different functional configurations.

- ▶ EMT Series - High torque and speed combination, for large diameter of valves.
  - Explosion proof type available.



- ▶ EMD Series - For standard control operation.



Product Features

Motor Protection



F class insulated motor. 2 built in temperature sensor to prevent over heat. (Class H motor can be customized).

Anti Moisture Protection



Standard built in anti moisture resistance to protect internal electronics from condensation.

Safe Manual Override



Manual override clutch to disengage motor and enables manual operation of the actuator.

Infrared Remote Control



Integration and Intelligent type come with infrared remote control for easy menu access.

Absolute Encoder



24 bits absolute encoder can record up to 1024 positions. This enables precise record of position even in lost power mode. Available on Integration and Intelligent type.

High Strength Worm Gear and Worm Shaft



High strength alloy worm shaft and gear for long durability. The meshing between worm shaft and gear had been specifically examined to ensure maximum efficiency.

High RPM output



High RPM enables applications on large diameter valves. EMD 18~144rpm, EMT 18~192rpm.

Non-Intrusive set up



Integration and Intelligent type can be set up by remote control. They also come with LCD display and local control button / knobs for easy access. Valve position can be set without opening actuator mechanically.

Performance Processor



Intelligent type adopts high performance micro processor, this which enables efficient and reliable monitoring of valve position/torque and operational status.

EMT Series



► Communication Field Bus

The configuration and composition of the electric actuator field bus control system are flexible and changeable, with strong applicability and expansion functions, and can effectively solve on-site problems related to interference noise, control distance, contact capacity and working environment. The field bus control system generally consists of the main control station, the communication loop and the field unit. The communication protocols currently supported by EMT series multi-turn electric actuators include Modbus, Profibus-DP, HART, etc.

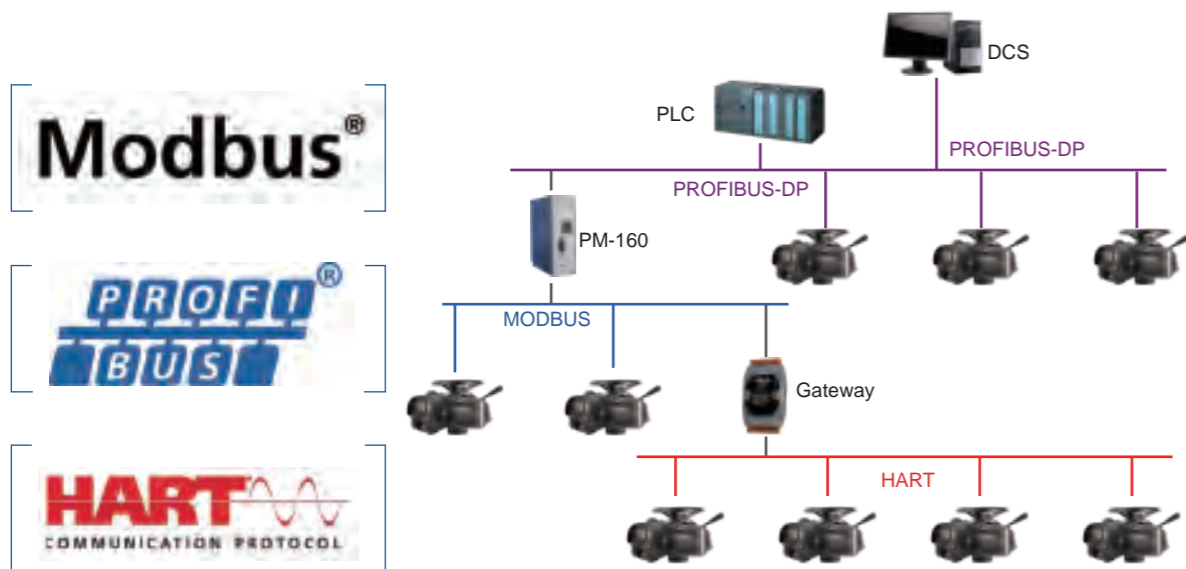

EMT Series

		BASIC	INTEGRATION	INTELLIGENT
<b>Control</b>	On-Off	✓	✓	✓
	Modulating	—	—	✓
<b>Protection</b>	Standard I P67, IP68 optional	✓	✓	✓
<b>Display</b>	Mechanical pointer	✓	—	—
	Open/Close/Remote/Fault indicator lamp	—	✓	✓
	LCD digital position percentage display	—	✓	✓
	LCD digital torque percentage display	—	—	✓
<b>Position Limit</b>	Registering gear	✓	—	—
	Absolute encoder	—	✓	✓
<b>Local Control</b>	Open/Stop/Close button, Local/Remote/Lock	—	—	✓
	Remote control	—	✓	✓
<b>Protection</b>	Over torque	✓	✓	✓
	Motor over heat	✓	✓	✓
	Valve stall	—	✓	✓
	Loss signal	—	—	✓
	Reverse starter	—	✓	✓
	Loss phase (3 phase only)	—	✓	✓
	Auto phase correction (3 phase only)	—	✓	✓
	Non intrusive set up	—	✓	✓
	Operational data log	—	—	✓
	Password	—	✓	✓
	Anti condensation ( Heater)	Optional	✓	✓
	<b>Feedback Signal</b>	Open and close position limit, open and close torque switch, position feedback potentiometer	✓	—
1 * Collective fault feedback, 5 *potentiometer feedback contact (Contact capacity 5A@250Vac)		—	✓	—
	Expansion potentiometer feedback contacts (Contact capacity 5A@250Vac)	—	—	✓
<b>Control Signal</b>	On-Off switch signal	✓	✓	✓
	Analogue signal (4-20mA, 0-10V, 2-10V)	—	—	✓
	Modbus, Profibus, HART	—	—	✓
<b>Other</b>	Non intrusive position limit set up	—	✓	✓
	Torque switch limit set up	—	—	✓
	Set up of: Deadzone, Reverse signal, Loss signal mode, (0%, 100%, keep); Feedback contacts, ESD (0%, 100%, Keep); Power loss display,	—	—	✓



EMT Series

		BASIC	INTEGRATION	INTELLIGENT
<b>Torque Range</b>		35-3000N.m		
<b>Speed</b>	50Hz	18、24、36、48、72rpm	18、24、36、48、72、96、144、192rpm	
	60Hz	21、29、43、57、86rpm	21、29、43、57、86、115、173、230rpm	
<b>Ambient Temperature</b>		-30°C~70°C, Optional -40°C~+55°C		
<b>Noise</b>		Within 1 meter < 75dB		
<b>Cable Entries</b>		2 x NPT3/4, 1 x NPT1 1/2		
<b>Ingress Protection</b>		IP67, Optional IP68 (7 meter under water for up to 72 hours)		
<b>Mounting</b>		ISO5210 (Rising type or non-rising type)		
<b>Motor</b>		Standard F class motor for heat protection up to 135°C		
<b>Duty Cycle</b>	On-Off	S2~15min (600 starts per hour)		
	Modulating	—	S4-25% (600 starts per hour)	
<b>Standard Voltage</b> (Other voltages can be customized)		3 phase 4 wires: 3 phase 380VAC (±10%) 50Hz/60Hz(±5%) Optional: 1 phase 220VAC	3 phase 3 wires: 3 phase 380VAC (±10%) 50Hz/60Hz(±5%) Optional: 1 phase 220VAC	
<b>Input Signal</b>	On-Off	Built in contacts 5A@250Vac	AC/DC 24V input; AC110/220V (optional); optical signal isolation	20-60V AC/DC or 60-120V AC, optical signal isolation
	Modulating	—	—	Input signal: 4 ~ 20 mA; 0 ~ 10 V; 2 ~ 10 V Accuracy: (1 %), Dead zone: 0 ~ 25.5% adjustable rate in full stroke Input impedance: 75 Ω (4~20 mA)
<b>Feedback Signal</b>	On-Off	<ul style="list-style-type: none"> <li>Opening stroke limit, closing stroke limit</li> <li>Opening over torque, closing over torque</li> <li>Flash signal(contact capacity: 5A at 250 V ac)</li> <li>Optional: Semi-modulating type-position feedback potentiometer</li> <li>Optional: 4 ~ 20 mA transmission</li> </ul>	<ul style="list-style-type: none"> <li>Local/remote contacts</li> <li>Integrated fault contact</li> <li>Close the valve contact</li> <li>Open the valve contact (contact capacity: 5 A at 250 V ac)</li> <li>Optional: Opening torque signal contact</li> <li>Optional: Closing torque signal contact</li> </ul>	Relay X 5 (4 can be set to "natural open" or "natural closed" contacts. 1 integrated fault contact) A. Single or multi-phase power down B. Control circuit power failure C. Selection switch is in place or the stop position D. Motor temperature protector jumps off
	Modulating	—	—	Input signal: 4 ~ 20 mA; 0 ~ 10 V; 2 ~ 10 V Output impedance: ≤750 Ω (4 ~ 20 mA) (Repeatability and linearity within ±1 % of full valve stroke)
<b>Fault Signal</b>	On-Off	<ul style="list-style-type: none"> <li>Integrated fault alarm: Motor overheating, over torque contacts</li> <li>Optional: Phase protection contact</li> </ul>	Collective fault alarm: Power off, motor overheating, lose phase, over torque, lose signal, ESD, terminal output	<ul style="list-style-type: none"> <li>Phase correction</li> <li>Torque switch</li> <li>Thermal protection</li> <li>Jammed valve protection</li> <li>Lose signal protection</li> <li>Instantaneous reverse protection</li> </ul>
	Modulating	—	—	Signal Reverse, Loss signal setting, Dead zone: 0~25.5% adjustable Time lag: 0~25.5% adjustable
<b>Position Display</b>		Mechanical Pointer	<ul style="list-style-type: none"> <li>LCD screen display</li> <li>Fully open/Fully close/remote / fault indicator</li> </ul>	<ul style="list-style-type: none"> <li>4-level grayscale LCD screen opening indicator</li> <li>Fully open/Fully close/remote/fault indicator</li> </ul>

Note: Single-phase applies only to EMT1-3 series

EMT Series

► EMT - 3 Phase voltage ON-OFF Control

Model	Speed (rpm)		Torque (N.m)	Max. Stem Diameter(mm)	
	50Hz	60Hz		A type	B type
EMT11	18	21	35	32	22
	24	29	35		
	36	43	35		
	48	57	35		
	72	86	35		
	96	115	35		
	*144	*173	30		
	*192	*230	25		
EMT12	18	21	80	32	22
	24	29	80		
	36	43	80		
	48	57	70		
	72	86	50		
	96	115	40		
	*144	*173	35		
	*192	*230	30		
EMT13	18	21	105	32	22
	24	29	105		
	36	43	100		
	48	57	90		
	72	86	60		
	96	115	50		
	*144	*173	40		
	*192	*230	35		
EMT21	18	21	200	47	32
	24	29	200		
	36	43	200		
	48	57	200		
	72	86	170		
	96	115	150		
	*144	*173	100		
	*192	*230	60		
EMT22	18	21	300	47	32
	24	29	300		
	36	43	250		
	48	57	220		
	72	86	200		
	96	115	170		
	*144	*173	120		
	*192	*230	80		
EMT23	18	21	400	47	32
	24	29	400		
	36	43	300		
	48	57	250		
	72	86	250		
	96	115	230		
	*144	*173	150		
	*192	*230	90		

## EMT Series

## ► EMT - 3 Phase voltage ON-OFF Control

Model	Speed (rpm)		Torque (N.m)	Max. Stem Diameter(mm)	
	50Hz	60Hz		A type	B type
EMT31	18	21	620	60	45
	24	29	620		
	36	43	550		
	48	57	480		
	72	86	480		
	96	115	370		
	*144	*173	250		
	*192	*230	200		
EMT41	18	21	1050	83	60
	24	29	1050		
	36	43	850		
	48	57	700		
	72	86	700		
	96	115	550		
	*144	*173	420		
	EMT42	18	21		
24		29	1500		
36		43	1300		
48		57	1050		
72		86	1050		
96		115	750		
*144		*173	650		
*192		*230	550		
EMT43	18	21	2050	83	60
	24	29	2050		
	36	43	1750		
	48	57	1400		
	72	86	1400		
	96	115	1050		
	*144	*173	880		
	*192	*230	750		
EMT44	18	21	3000	83	60
	24	29	3000		
	*144	*173	1360		
	*192	*230	1360		

Note:

1. The above torque is the maximum torque of electric actuator, if you have special output torque and speed requirements, please contact us.
2. The current frequency of the above products is 50Hz.
3. The above products are based on EN15714-2-2009 Class A and B. The working system of EMT1-3 series is S2-15min, and the working system of EMT4 series is S2-10min.
4. With "\*" speed inertia is large, not recommended for direct drive gate valves and other similar applications. For multi-turn electric actuators with A-type lifting nut valve connection mechanism, the maximum shaft speed (output speed) is allowed. Must comply with: a. 500mm/min max. for gate valves b. 250mm/min max. for globe valves (45rpm max.)
5. Optional for regulating type, starting frequency 25% and below, no more than 600 starts per hour.
6. EMT series manual speed ratio is 1:1, if equipped with manual reducer, the manual speed ratio will be changed accordingly, please consult our salesman for detailed parameters.

## EMT Series

## ► EMT - 3 Phase voltage Modulating Control

Model	Speed (rpm)		Torque (N.m)	Max. Stem Diameter(mm)	
	50Hz	60Hz		A type	B type
EMT11	18	21	35	32	22
	24	29	35		
	36	43	31		
	48	57	28		
	72	86	25		
EMT12	18	21	60	32	22
	24	29	60		
	36	43	50		
	48	57	45		
EMT13	18	21	80	32	22
	24	29	80		
	36	43	72		
	48	57	65		
	72	86	50		
EMT21	18	21	160	47	32
	24	29	160		
	36	43	140		
	48	57	110		
	72	86	90		
EMT22	18	21	240	47	32
	24	29	240		
	36	43	200		
	48	57	170		
EMT23	18	21	300	47	32
	24	29	300		
	36	43	260		
	48	57	210		
	72	86	190		
EMT31	18	21	550	60	45
	24	29	550		
	36	43	510		
	48	57	410		
	72	86	380		

Note:

1. The above adjustment torque is 1/2 of the maximum torque of the electric actuator.
2. The above products are based on Class C and D as described in EN15714-2-2009, the standard starting frequency is 50%, not more than 1200 starts per hour, if you have special needs, please contact us.
3. EMT series regular manual speed ratio is 1:1, if equipped with manual gearbox, the manual speed ratio has corresponding changes, detailed parameters can consult our sales staff.

## EMT Series

### EMT 系列单相开关型 (AC220V)

Mode	Speed (rpm)		Torque (N.m)	Max. Stem Diameter(mm)	
	50Hz	60Hz		Type A	Type B
EMT11	18	21	60	32	22
	24	29	60		
	36	43	50		
	48	57	50		
	72	86	35		
EMT12	24	29	120	32	22
	36	43	100		
	48	57	80		
	72	86	50		
EMT21	18	21	150	47	32
	24	29	150		
	36	43	130		
	48	57	100		
	72	86	50		
EMT22	24	29	220	47	32
	36	43	180		
	48	57	150		
	72	86	110		
EMT31	18	21	250	60	45
	24	29	250		
	36	43	200		
	48	57	170		
	72	86	130		
	96	115	100		

- Note:
1. The above torque is the maximum torque of the actuator, if you have special output torque and speed requirements, please contact us.
  2. The above products are based on Class A and B according to EN15714-2-2009, and the working system is S2-10min.
  3. EMT series manual speed ratio is 1:1, if equipped with manual gearbox, the manual speed ratio will be changed accordingly, please consult our salesman for detailed parameters.

### EMT Series Order code

EMT 11-18-O-eB-E00-S-K9.4-F07A-\*

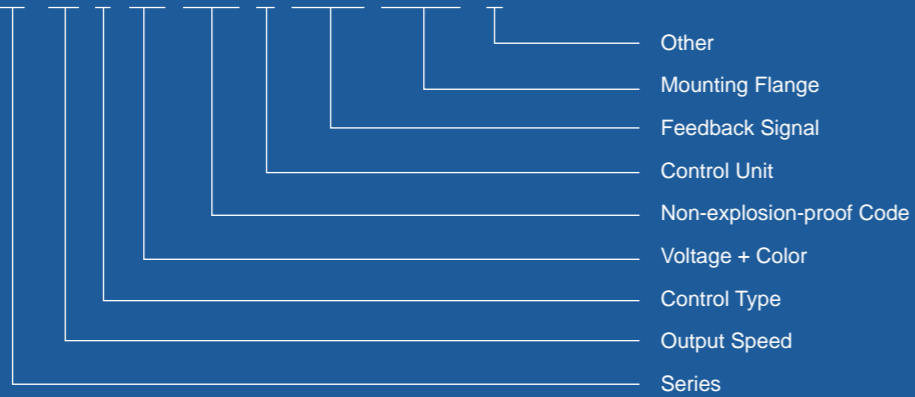

## EMT Series

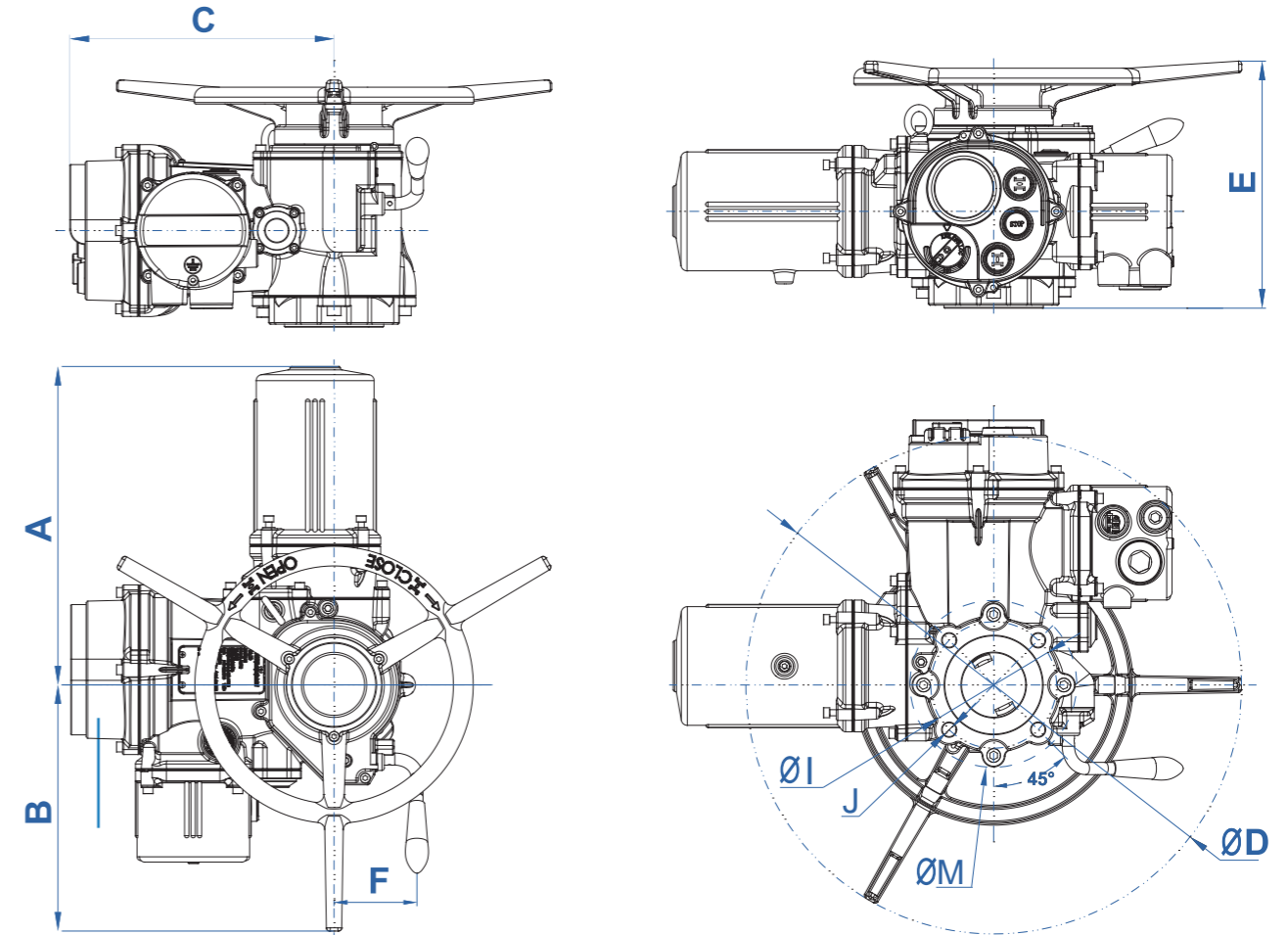

Unit: mm

Model	Dimension				E		F	ØI	ØM	J	Weight(kg)
	A	B	C	ΦD	Type A	Type B					
EMT11/12/13	330	254	310	300	310	282	90	102	120	4-M10	25
EMT21/22/23	384	283	331	509	335	303	111	140	175	4-M16	42
EMT31	420	325	346	650	355	323	111	165	205	4-M20	60
EMT41/42/43/44	580	465	510	930	568	520	140	298	335	8-M20	175

- Note:
1. Above connection size is in comply to ISO5210. For special requirement can be customized.
  2. A type is for rising type valve stem, B type is for non-rising type valve stem.

EMT Series

▶ EMT A type valve stem (Rising type)

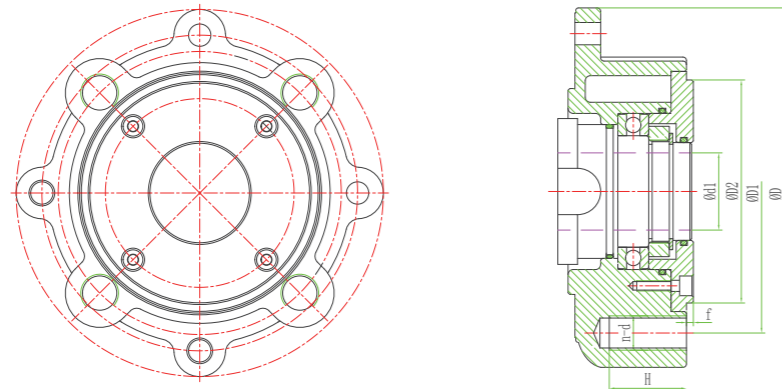

Model	Size	Flange	ΦD	ΦD1	ΦD2	f	Φd1 (MAX)	Φd1 (STD)	n-d	a	H
EMT11/12/13		F10	120	102	70	3.5	Φ32	≤Φ22	4-M10	45°	15
EMT21/22/23		F14	175	140	100	4	Φ47	≤Φ32	4-M16	45°	24
EMT31		F16	205	165	130	5	Φ60	≤Φ45	4-M20	45°	30
EMT41/42/43/44		F30	338	298	230	5	Φ82	≤Φ70	4-M20	22.5°	30

▶ EMT B type valve stem (Rotary type)

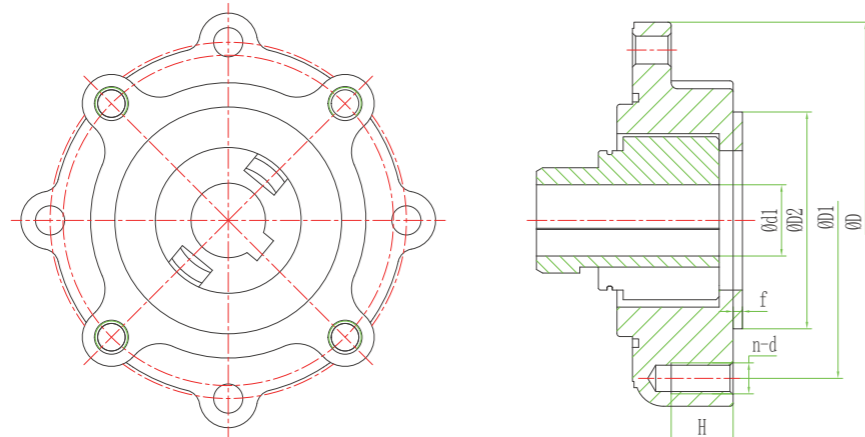

Model	Size	Flange	ΦD	ΦD1	ΦD2	f	Φd1 (MAX)	Φd1 (STD)	n-d	a	H
EMT11/12/13		F10	120	102	70	3.5	Φ22	≤Φ20	4-M10	45°	15
EMT21/22/23		F14	175	140	100	4	Φ32	≤Φ30	4-M16	45°	24
EMT31		F16	205	165	130	5	Φ45	≤Φ40	4-M20	45°	30
EMT41/42/43/44		F30	338	298	230	5	Φ60	≤Φ50	4-M20	22.5°	30

Note: EMT11/12/13 flanges are available in F07; EMT21/22/23 flanges are available in F10.

EMT Series

▶ EMT Series general parameters

Anti-corrosion protection:	Epoxy powder coating. Can be customized according to customer requirements.
Ingress protection:	IP67 protection grade, optional IP68 (7m underwater, 72 hours without leakage).
Ambient temperature:	Omeax high temperature fire hood to meet special use requirements. (Can be customized according to customer requirements.)
Relative humidity:	-30 C~70 C。 optional:-40 C~55 C。
Ambient temperature:	≤95% (25 C)。

EMT系列

▶ EMT Series explosion-proof grade parameters



Ex db IIB/IIC T4 Gb/Ex tb IIIC T130°Db
Temperature: -40°~+60°C; optional:-20°~+55°C
GB/T 3836.1 Ex db IIB/IIC T6 Gb
GB/T 3836.2 Ex tb IIIC T80°Db
GB/T 3836.3





EMD Series

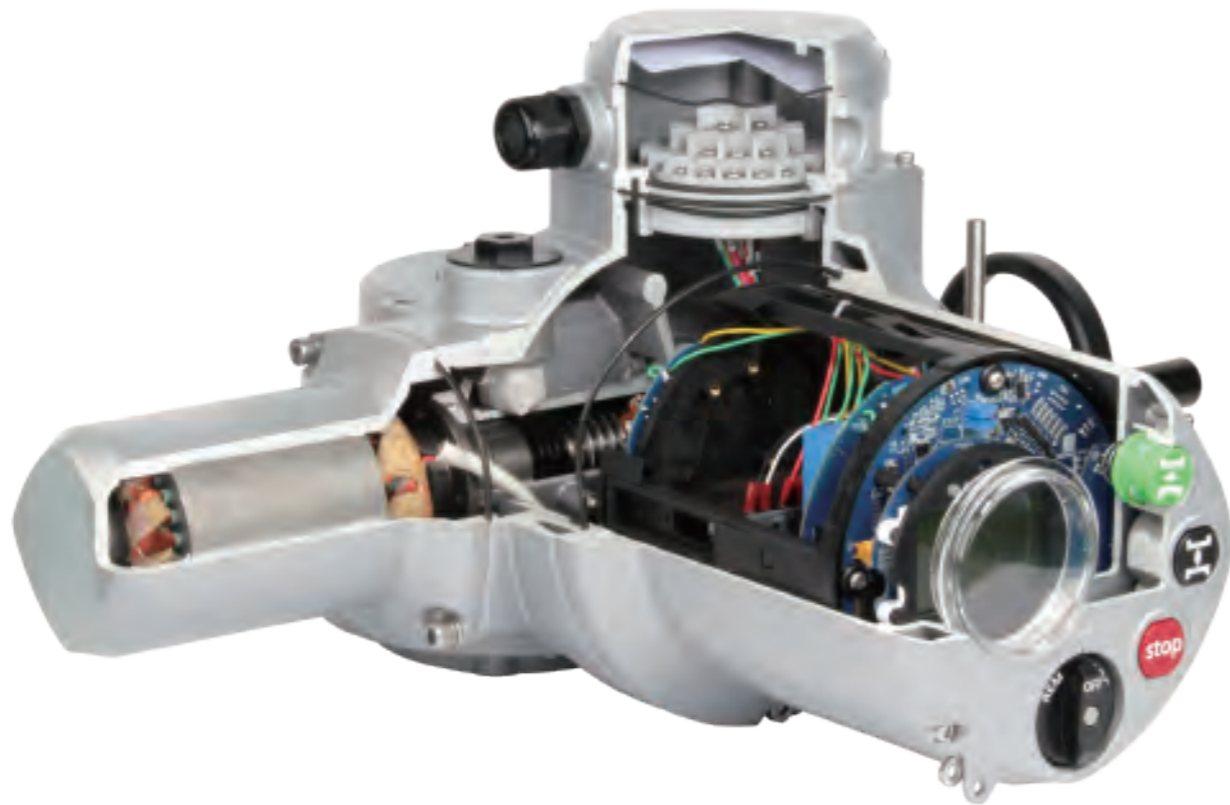

**1**  
EMD series multi-turn electric actuators are designed for multi-turn or linear motion valves such as gate valves, globe valves, control valves and other similar valve applications. It can also be used with a 90° worm gearbox to drive quarter turn valves such as butterfly valves, ball valves, plug valves and other similar valves.

**2**  
The direct output torque of EMD series with a wide range from 40N.m~900N.m, and the output speed is 18~144rpm. Combine with gearbox, it can output more torque to meet the torque requirements of large diameter high torque valve applications.

**3**  
Omeax multi-turn EMD series can provide suitable solutions from conventional standard models for basic industrial needs to intelligent models that can perform configuration settings and intelligent feedback for various applications.

- 4**
- Aluminum alloy housing
  - Speed: 18~144rpm
  - High cost performance
  - Intelligent: LCD display,
  - Non-intrusive setting
  - Standard IP67 protection



EMD Series

		BASIC	INTEGRATION	INTELLIGENT	
<b>Control</b>	On-Off	✓	✓	✓	
	Modulating	—	✓	✓	
<b>Protection</b>	Standard IP67, IP68 optional	✓	—	—	
	Standard IP68	—	✓	✓	
<b>Display</b>	Mechanical pointer	✓	—	—	
	Open/Close/Remote/Fault indicator lamp	—	✓	✓	
	LCD digital position percentage display	—	✓	✓	
	LCD digital torque percentage display	—	—	✓	
<b>Position Limit</b>	Registering gear	✓	—	—	
	Absolute encoder	—	✓	✓	
<b>Local Control</b>	Open/Stop/Close button, Local/Remote/Lock	—	✓	✓	
	Remote control	—	✓	✓	
<b>Protection</b>	Over torque	✓	✓	✓	
	Motor over heat	✓	✓	✓	
	Valve stall	—	✓	✓	
	Loss signal	—	✓	✓	
	Reverse starter	—	✓	✓	
	Loss phase (3 phase only)	—	✓	✓	
	Auto phase correction (3 phase only)	—	✓	✓	
	Non intrusive set up	—	✓	✓	
	Operational data log	—	—	✓	
	Password	—	✓	✓	
	Anti condensation ( Heater)	Optional	✓	✓	
	<b>Feedback Signal</b>	Open and close position limit, open and close torque switch, position feedback potentiometer	✓	—	—
		1 * Collective fault feedback, 5 *potentiometer feedback contact (Contact capacity 5A@250Vac)	—	✓	✓
	<b>Control Signal</b>	On-Off switch signal	✓	✓	✓
Analogue signal (4-20mA, 0-10V, 2-10V)		—	✓	✓	
Modbus, Profibus, HART		—	✓	✓	
<b>Other</b>	Non intrusive position limit set up	—	✓	✓	
	Torque switch limit set up	—	—	✓	
	Set up of: Deadzone, Reverse signal, Loss signal mode, (0%, 100%, keep); Feedback contacts, ESD (0%, 100%, Keep);	—	✓	✓	
	Power loss display,	—	—	✓	

**EMD Series**

		BASIC	INTEGRATION	INTELLIGENT
<b>Model Range</b>		EMD05-EMD90		EMD10-EMD90
<b>Speed</b>	50Hz	18、24、36、48、72rpm	18、24、36、48、72、96、144rpm	
	60Hz	21、29、43、57、86rpm	21、29、43、57、86、115、173rpm	
<b>Ambient Temperature</b>		-30°C~70°C		
<b>Noise</b>		Within 1 meter < 75dB		
<b>Cable Entries</b>		Standard 2-NPT3/4" (2-NPT1" available) Option 3-NPT3/4" (3-NPT1" available)		Standard 2-NPT1" & 1-NPT3/4" Optional 3-NPT1" & 1-NPT1 1/2"
<b>Ingress Protection</b>		Standard IP67 Optional IP68	Standard IP68	
<b>Mounting</b>		JB2920(Standard), ISO5210 (Optional A type or B type)		
<b>Motor</b>		Standard F class motor for heat protection up to 135°C		
<b>Duty Cycle</b>	On-Off	S2~15min (600 starts per hour)		
	Modulating	—	S4-25% (600 starts per hour)	
<b>Standard Voltage</b> (Other voltages can be customized)		3 phase: AC380V (±10%) 1 phase: AC220V Frequency: 50Hz/60Hz(±5%)		
<b>Input Signal</b>	On-Off	Built in contacts 5A@250Vac	AC/DC 24V input; AC110/220V (optional); optical signal isolation	
	Modulating	—	Input signal: 4 ~ 20 mA; 0 ~ 10 V; 2 ~ 10 V Input impedance: 150Ω (4~20 mA)	
<b>Feedback Signal</b>	On-Off	<ul style="list-style-type: none"> <li>Open stroke limit, close stroke limit</li> <li>Open over torque, close over torque</li> <li>Flash signal (contact capacity: 5A at 250V ac)</li> <li>Position feedback potentiometer</li> </ul>	5 configurable contacts, 1 integrated fault contact (Contact capacity 5A@250Vac)	
	Modulating	—	Input signal: 4~20 mA; 0~10V; 2~10V Output impedance: ≤750Ω (4~20 mA) (Repeatability and linearity within ±1 % of full valve stroke)	
<b>Fault Signal</b>	On-Off	<ul style="list-style-type: none"> <li>Integrated fault alarm: Motor overheating, over torque contacts</li> </ul>	Collective fault alarm: Power off, motor overheating, lost phase, over torque, lose signal,	
	Modulating	—	Signal Reverse, Dead zone: ≤2%	
<b>Position Display</b>		Mechanical Pointer	<ul style="list-style-type: none"> <li>LCD screen display</li> <li>Position percentage display</li> </ul>	<ul style="list-style-type: none"> <li>4-level grayscale LCD screen opening indicator</li> <li>Position percentage display</li> <li>Torque percentage display</li> </ul>

- Note:
- EMD90 three-phase unregulated type, single-phase 220V unregulated type.
  - IP68 protection level is defined as underwater 7m, 72 hours without leakage.

**EMD Series**

► **EMD - 3 Phase voltage ON-OFF Control**

Model	Speed (rpm)		Torque (N.m)	Handwheel Ratio	Max. Stem Diameter (mm)
	50Hz	60Hz			
EMD05	18	21	50	80:1	≤30
	24	29	50	60:1	
	36	43	50	40:1	
	48	57	50	30:1	
	72	86	40	20:1	
EMD10	18	21	100	80:1	≤30
	24	29	100	60:1	
	36	43	100	40:1	
	48	57	100	30:1	
	72	86	70	20:1	
	96	115	50	40:1	
EMD15	*144	*173	40	20:1	≤30
	18	21	150	80:1	
	24	29	150	60:1	
	36	43	150	40:1	
	48	57	120	30:1	
	72	86	100	20:1	
EMD20	96	115	75	40:1	≤42
	*144	*173	60	20:1	
	18	21	200	80:1	
	24	29	200	60:1	
	36	43	200	40:1	
	48	57	200	30:1	
EMD30	72	86	170	20:1	≤42
	96	115	150	40:1	
	*144	*173	100	20:1	
	18	21	300	80:1	
	24	29	300	60:1	
	36	43	300	40:1	
EMD40	48	57	250	30:1	≤42
	72	86	200	20:1	
	96	115	170	40:1	
	*144	*173	120	20:1	
	18	21	400	80:1	
	24	29	400	60:1	
EMD40	36	43	350	40:1	≤42
	48	57	300	30:1	
	72	86	250	20:1	
	96	115	230	40:1	
	*144	*173	150	20:1	

- Note:
- Above torque is maximum torque of actuator.
  - Motor duty cycle S2-15min, 3 phase 380VAC.
  - RPM with "\*" has higher momental force, not recommended for direct drive of valve.

**EMD Series**

► **EMD - 3 Phase voltage ON-OFF Control**

Model	Speed (rpm)		Torque (N.m)	Handwheel Ratio	Max. Stem Diameter (mm)
	50Hz	60Hz			
EMD50	18	21	500	80:1	≤50
	24	29	500	60:1	
	36	43	500	40:1	
	48	57	500	30:1	
	72	86	400	20:1	
	96	115	300	40:1	
	*144	*173	200	20:1	
EMD60	18	21	610	80:1	≤50
	24	29	610	60:1	
	36	43	610	40:1	
	48	57	550	30:1	
	72	86	450	20:1	
	96	115	330	40:1	
	*144	*173	260	20:1	
EMD90	18	21	900	80:1	≤50
	24	29	900	60:1	
	36	43	750	40:1	
	48	57	600	30:1	
	72	86	480	20:1	
	96	115	350	40:1	

- Note:
1. Above torque is maximum torque of actuator.
  2. Motor duty cycle S2-15min, 3 phase 380VAC.
  3. RPM with "\*" has higher momental force, not recommended for direct drive of valve.

► **EMD - 1 Phase 220VAC ON-OFF Control**

Model	Speed (rpm)		Torque (N.m)	Handwheel Ratio	Max. Stem Diameter (mm)
	50Hz	60Hz			
EMD10	18	21	60	80:1	≤30
	24	29	60	60:1	
	36	43	50	40:1	
	48	57	50	30:1	
	72	86	35	20:1	
EMD40	18	21	150	80:1	≤42
	24	29	150	60:1	
	36	43	130	40:1	
	48	57	100	30:1	
	72	86	50	20:1	
EMD60	18	21	250	80:1	≤50
	24	29	250	60:1	
	36	43	200	40:1	
	48	57	170	30:1	
	72	86	130	20:1	

- Note:
1. EMD single-phase unregulated type
  2. The above torque is the maximum torque of electric actuator, motor working system is S2-10min, power supply is single-phase 220VAC

**EMD Series**

► **EMD - 3 Phase voltage Modulating Control**

Model	Speed (rpm)		Torque (N.m)	Handwheel Ratio	Max. Stem Diameter (mm)
	50Hz	60Hz			
EMD05	18	21	50	80:1	≤30
	24	29	50	60:1	
	36	43	50	40:1	
	48	57	50	30:1	
	72	86	40	20:1	
EMD10	18	21	100	80:1	≤30
	24	29	100	60:1	
	36	43	100	40:1	
	48	57	100	30:1	
	72	86	70	20:1	
EMD15	18	21	150	80:1	≤30
	24	29	150	60:1	
	36	43	150	40:1	
	48	57	120	30:1	
	72	86	100	20:1	
EMD20	18	21	200	80:1	≤42
	24	29	200	60:1	
	36	43	200	40:1	
	48	57	200	30:1	
	72	86	170	20:1	
EMD30	18	21	300	80:1	≤42
	24	29	300	60:1	
	36	43	300	40:1	
	48	57	250	30:1	
	72	86	200	20:1	
EMD40	18	21	400	80:1	≤42
	24	29	400	60:1	
	36	43	350	40:1	
	48	57	300	30:1	
	72	86	250	20:1	
EMD50	18	21	500	80:1	≤50
	24	29	500	60:1	
	36	43	500	40:1	
	48	57	500	30:1	
	72	86	400	20:1	
EMD60	18	21	610	80:1	≤50
	24	29	610	60:1	
	36	43	610	40:1	
	48	57	610	30:1	
	72	86	500	20:1	

- Note:
1. Above torque is maximum torque of actuator.
  2. Motor duty cycle S4-25%, 3 phase 380VAC.
  3. For modulating model selection torque safety factor up to 1.8-2 must be considered.
  4. Modulating control is only available on Intelligent model.

**EMD Series**

► **EMD - Basic type dimension**

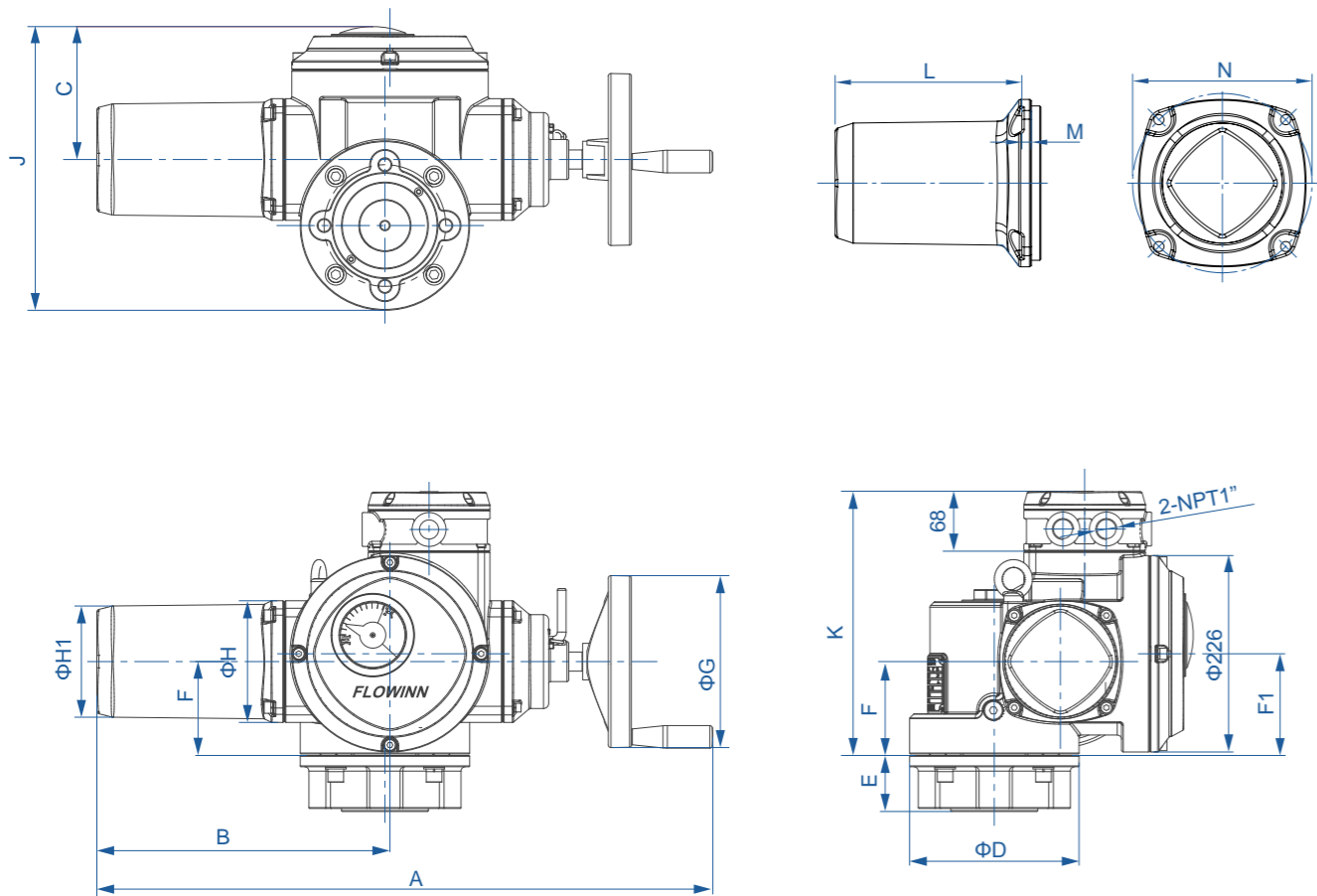

Dimension		Unit: mm																	
Model	Size	A	B	C	ΦD	E			F	F1	ΦG	ΦH	ΦH1	J	K	L	M	N	Weight (KG)
						JB	Type A	Type B											
EMD05/10/15		600	280	132	145	2	50	40	111	120	100	140	98	283	307	156	8	150	30
EMD20/30/40		710	338	153	195	2	65	42	114	117	200	140	128	327	303	204	12	150	36
EMD50/60/90		760	382	160	234	2	65	42	114	118	200	161	148	382	303	221	15	172	47

- Note:
1. Above connection size is in comply to ISO5210. For special requirement can be customized.
  2. A type is for rising type valve stem, B type is for non-rising type valve stem.
  - 3.Speed is 144rpm without basic type.

**EMD Series**

► **EMD - Integration type dimension**

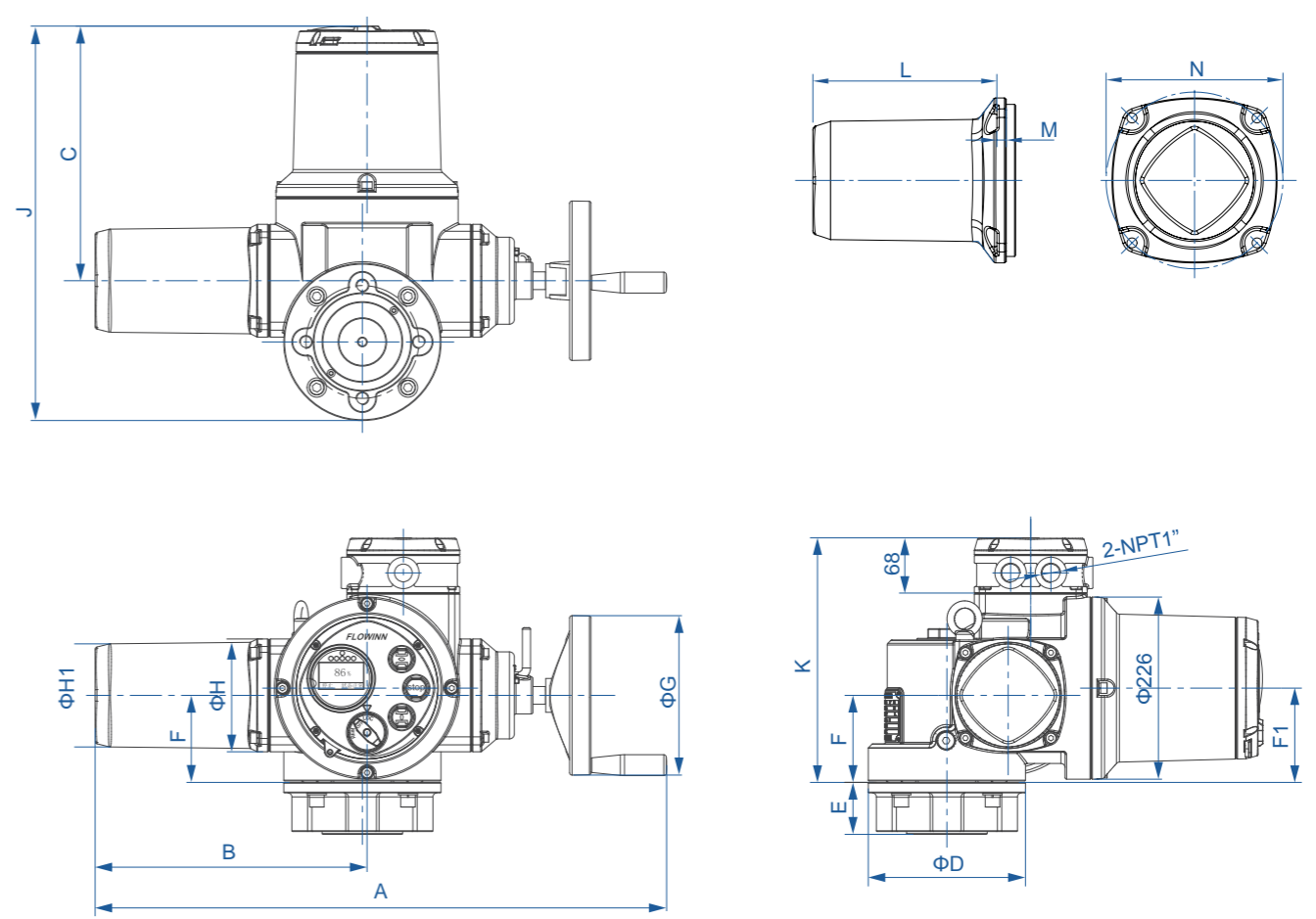

Dimension		Unit: mm																	
Model	Size	A	B	C	ΦD	E			F	F1	ΦG	ΦH	ΦH1	J	K	L	M	N	Weight (KG)
						JB	Type A	Type B											
EMD05/10/15		600	280	316	145	2	50	40	111	120	100	140	98	446	307	156	8	150	30
EMD20/30/40		710	338	316	195	2	65	42	108	117	200	140	128	490	303	204	12	150	36
EMD50/60/90		760	382	332	234	2	65	42	114	118	200	161	148	545	303	221	15	172	47

- Note:
1. Above connection size is in comply to ISO5210. For special requirement can be customized.
  2. A type is for rising type valve stem, B type is for non-rising type valve stem.



EMD Series

► EMD - Intelligent type dimension

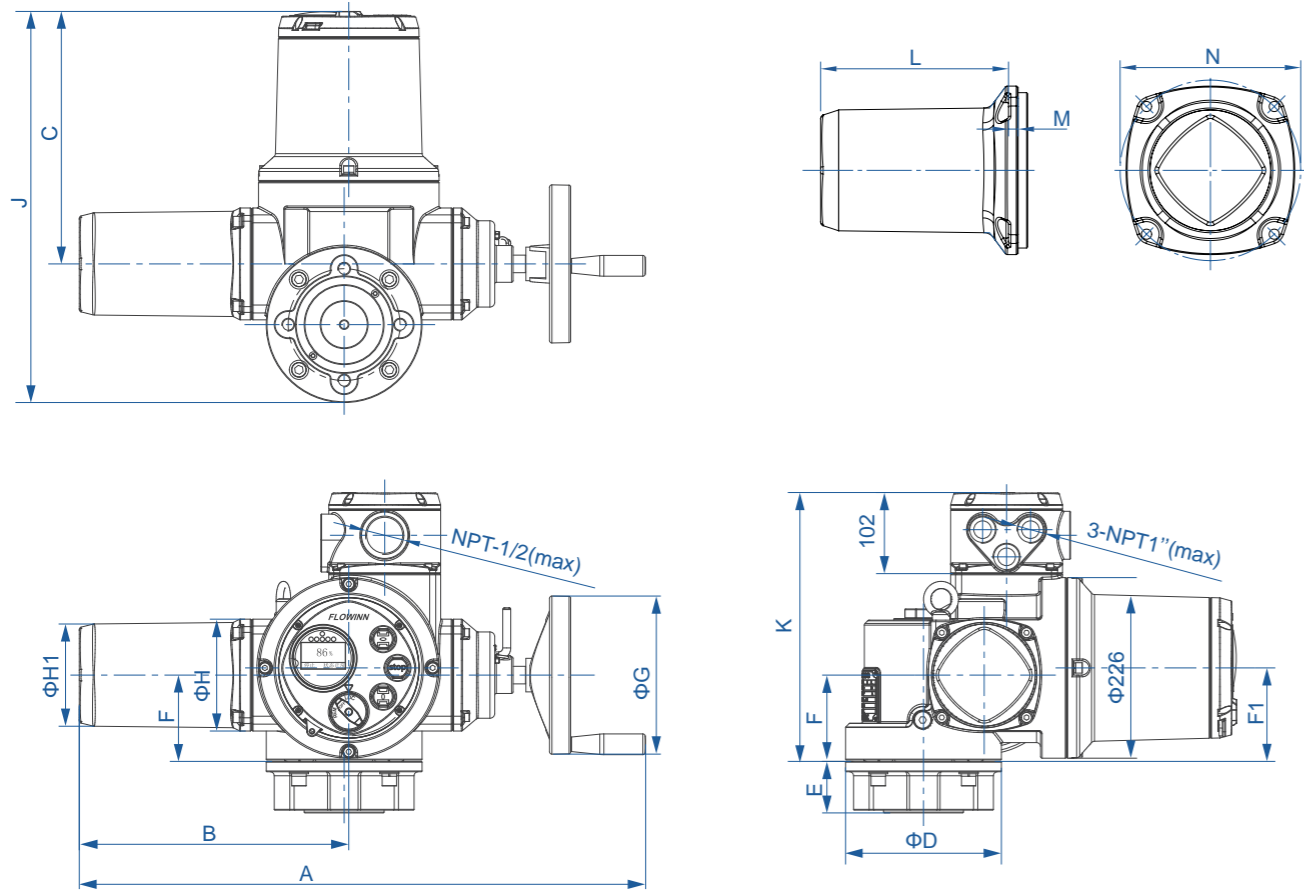

Dimension

Unit: mm

Model	Size	A	B	C	ΦD	E			F	F1	ΦG	ΦH	ΦH1	J	K	L	M	N	Weight (KG)
						JB	Type A	Type B											
EMD10/15		600	280	316	145	2	50	40	111	120	100	140	98	446	341	156	8	150	30
EMD20/30/40		710	338	316	195	2	65	42	108	117	200	140	128	490	337	204	12	150	36
EMD50/60/90		760	382	332	234	2	65	42	114	118	200	161	148	545	337	221	15	172	47

- Note:  
 1. Above connection size is in comply to ISO5210. For special requirement can be customized.  
 2. A type is for rising type valve stem, B type is for non-rising type valve stem.

EMD Series

► EMD - JB type output (rotary type) - JB2920

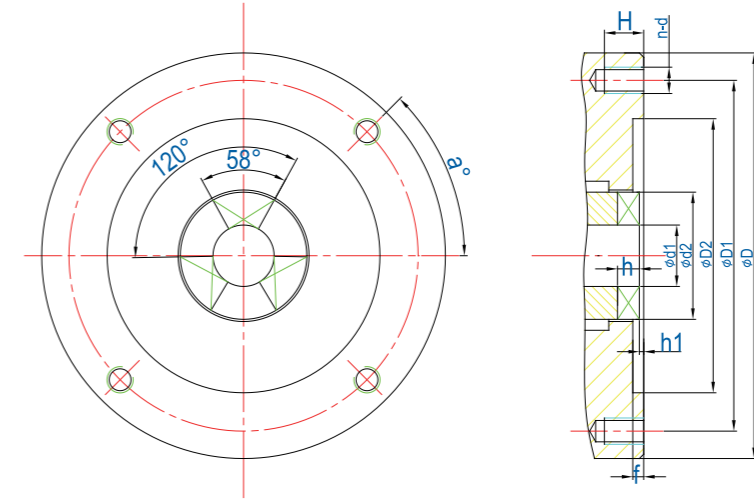

Model	Size	Base	ΦD	ΦD1	ΦD2	h1	f	h	φd1	φd2	n-d	a	H
EMD05/10/15		JB2	145	120	90	2	5	8	≤Φ30	Φ45	4-M10	45°	15
EMD20/30/40		JB3	185	160	125	2	5	10	≤Φ42	Φ58	4-M12	45°	15
EMD50/60/90		JB4	225	195	150	2	5	12	≤Φ50	Φ72	4-M20	45°	30

► EMD - A type output (Rising type) - ISO5210

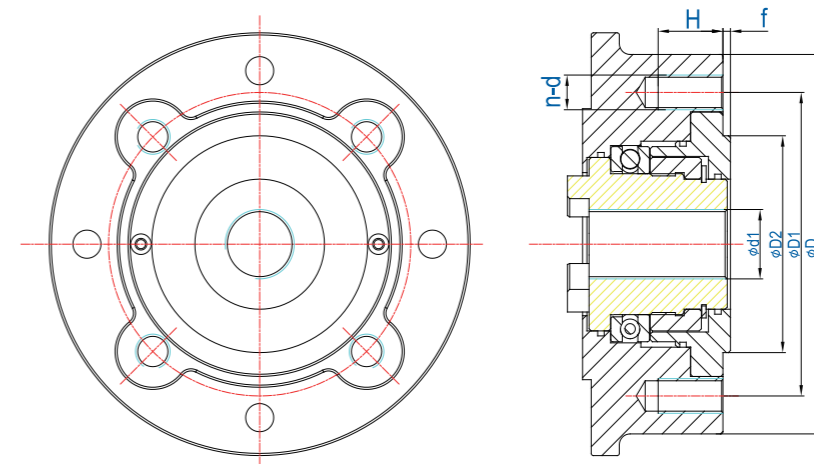

Model	Size	Flange	ΦD	ΦD1	ΦD2	f	φd1	n-d	a	H
EMD05/10/15		F10	120	102	70	3	≤Φ30	4-M10	45°	15
EMD20/30/40		F14	175	140	100	4	≤Φ42	4-M16	45°	24
EMD50/60/90		F16	205	165	135	5	≤Φ50	4-M20	45°	30

## EMD Series

### ▶ EMD - B type output (Rotary type) - ISO5210

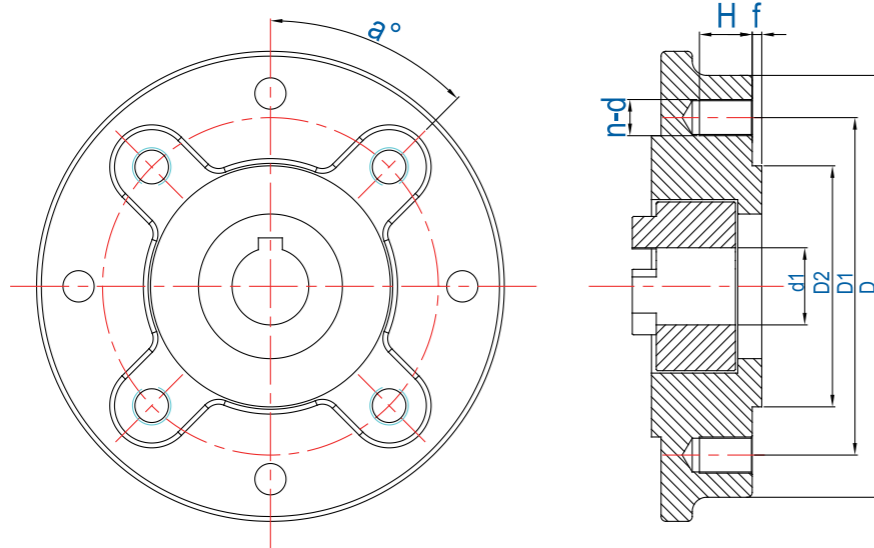

Model	Size	Flange	ΦD	ΦD1	ΦD2	f	Φd1	n-d	a	H
EMD05/10/15		F10	120	102	70	3	≤Tr30	4-M10	45°	15
EMD20/30/40		F14	175	140	100	4	≤Tr42	4-M16	45°	24
EMD50/60/90		F16	205	165	135	5	≤Tr50	4-M16	45°	30

### ▶ EMD Series Order code

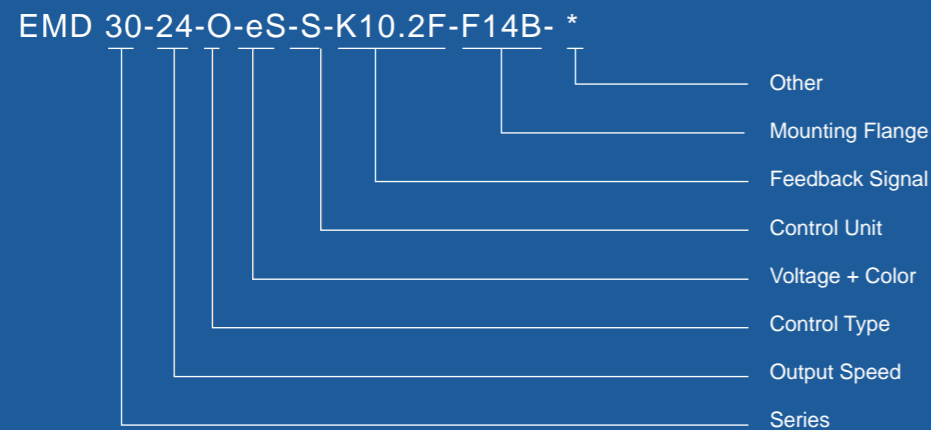

## Quality & Service

Omeax professional team is ready to provide users with comprehensive services and professional technical supports at all time:

- No matter is it by phone, mail or on the site, we are standing by for your inquiry.
- Reliable lead time & delivery
- On -site installation and debugging
- Regularly follow up our products status and maintenance.
- We provide training for structure knowledge,operation, debugging, maintenance and more
- For special requirements, we provide customized solutions.