

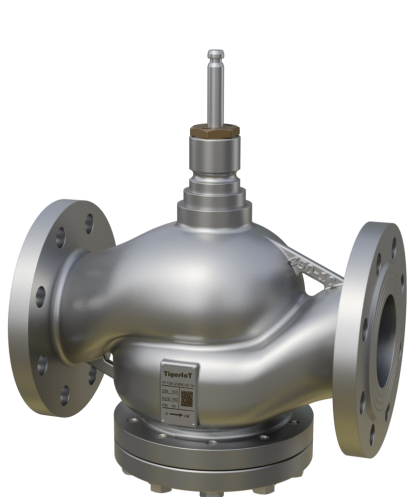

Control valves - Globe type - Stainless steel -
 flanged 2/3ways
 - TC103 16 bars - TC104 25 bars





**2-port
DN65~DN150**



**3-port mixing
DN65~DN150**

Features Introduction

- **High Quality Stainless Steel Material**

The valve body is made of stainless steel such as 304, 316, 316L and dual phase steel 2205310S, which has better strength and corrosion resistance.

- **Low Leakage Rate**

A metal hard seal is used between the valve seat and valve core, which can effectively prevent damage from impurities in the medium and ensure the leakage rate of the valve after long-term use.

- **High Close-off DP**

The maximum closing pressure difference of the valve can reach 16 bar.

- **V-shaped Sealing Ring & Spring Auto Compensation**

The shape of the sealing ring at the valve stem is V-shaped, which exhibits the effect of inner hole contraction and outer circle expansion under spring pressure, ensuring the long-term effectiveness of the valve stem seal.

- **Wide Flow Channel, Low Noise**

Smooth wide channel design effectively reduces valve noise.

It is suitable for ionized water, ethylene glycol solution, industrial refrigerant, and steam, it can be applied in working conditions with high requirements for hygiene level or corrosion resistance.



Electronic Workshop



Pharmaceutical Factory



Food Industry



Petroleum/Chemical Plant



Type Overview

PN16 Series

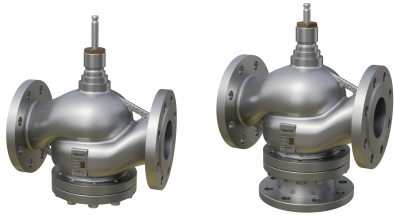

Series

	TW1001...	TW3000...	TW5000...
Actuator Rated Stroke	50mm	50mm	70mm
Nominal Output Force	1000N	3000N	5000N

icon



Valve Body	Medium Temperature	Type	DN [mm]	Stroke [mm]	Max. Flow Coefficient Kvs [m ³ /h]	ΔPs [kPa]	ΔPs [kPa]	ΔPs [kPa]
 2-port Water Valve	-25~150°C	TF65-2VBC-S.14	DN65	20	63	1600		
		TF80-2VBC-S.14	DN80	30	100	1600		
		TF100-2VBC-S.14	DN100	40	160		1600	
		TF125-2VBC-S.14	DN125	40	250		1600	
		TF150-2VBC-S.14	DN150	40	350		1600	
 2-port Steam Valve	2~180°C	TF65-2SBC-S.14	DN65	20	63		1600	
		TF80-2SBC-S.14	DN80	30	100		1600	
		TF100-2SBC-S.14	DN100	40	160		1600	
		TF125-2SBC-S.14	DN125	40	250		1600	
		TF150-2SBC-S.14	DN150	40	350		1600	
 2-port High-temp. Steam Valve	2~250°C	TF65-2ABC-S.14	DN65	20	63		1600	
		TF80-2ABC-S.14	DN80	30	100		1600	
		TF100-2ABC-S.14	DN100	40	160		1600	
		TF125-2ABC-S.14	DN125	40	250		1600	
		TF150-2ABC-S.14	DN150	40	350		1600	
 3-port mixing Water Valve	-25~150°C	TF65-3VBC-HS.14	DN65	20	63		900	
		TF80-3VBC-HS.14	DN80	30	100		550	
		TF100-3VBC-HS.14	DN100	40	160		350	
		TF125-3VBC-HS.14	DN125	40	250		240	350
		TF150-3VBC-HS.14	DN150	40	350		150	250
 2-port mixing Steam Valve	2~180°C	TF65-3SBC-HS.14	DN65	20	63		900	
		TF80-3SBC-HS.14	DN80	30	100		550	
		TF100-3SBC-HS.14	DN100	40	160		350	
		TF125-3SBC-HS.14	DN125	40	250		240	350
		TF150-3SBC-HS.14	DN150	40	350		150	250

Remark: The above valve material is 304 stainless steel, and 316, 316L, duplex steel 2205, or duplex steel 310S can also be selected. The example models are as follows: if the valve is 316L stainless steel, the model is TF ** -2VBC316L-S.14, and the specific model can also be consulted with the local office.



Type Overview

PN25 Series					Series	TW1001...	TW3000...	TW5000...
					Actuator Rated Stroke	50mm	50mm	70mm
					Nominal Output Force	1000N	3000N	5000N
					icon			
Valve Body	Medium Temperature	Type	DN [mm]	Stroke [mm]	Max. Flow Coefficient Kvs [m³/h]	ΔPs [kPa]	ΔPs [kPa]	ΔPs [kPa]
 2-port Water Valve	-25~150°C	TF65-2VBD-S.14	DN65	20	63	1600		
		TF80-2VBD-S.14	DN80	30	100	1600		
		TF100-2VBD-S.14	DN100	40	160		1600	
		TF125-2VBD-S.14	DN125	40	250		1600	
		TF150-2VBD-S.14	DN150	40	350		1600	
 2-port Steam Valve	2~180°C	TF65-2SBD-S.14	DN65	20	63		1600	
		TF80-2SBD-S.14	DN80	30	100		1600	
		TF100-2SBD-S.14	DN100	40	160		1600	
		TF125-2SBD-S.14	DN125	40	250		1600	
		TF150-2SBD-S.14	DN150	40	350		1600	
 2-port High-temp. Steam Valve	2~250°C	TF65-2ABD-S.14	DN65	20	63		1600	
		TF80-2ABD-S.14	DN80	30	100		1600	
		TF100-2ABD-S.14	DN100	40	160		1600	
		TF125-2ABD-S.14	DN125	40	250		1600	
		TF150-2ABD-S.14	DN150	40	350		1600	
 3-port mixing Water Valve	-25~150°C	TF65-3VBD-HS.14	DN65	20	63		900	
		TF80-3VBD-HS.14	DN80	30	100		550	
		TF100-3VBD-HS.14	DN100	40	160		350	
		TF125-3VBD-HS.14	DN125	40	250		240	350
		TF150-3VBD-HS.14	DN150	40	350		150	250
 2-port mixing Steam Valve	2~180°C	TF65-3SBD-HS.14	DN65	20	63		900	
		TF80-3SBD-HS.14	DN80	30	100		550	
		TF100-3SBD-HS.14	DN100	40	160		350	
		TF125-3SBD-HS.14	DN125	40	250		240	350
		TF150-3SBD-HS.14	DN150	40	350		150	250

Remark: The above valve material is 304 stainless steel, and 316, 316L, duplex steel 2205, or duplex steel 310S can also be selected. The example models are as follows: if the valve is 316L stainless steel, the model is TF * * -2VBC316L-S.14, and the specific model can also be consulted with the local office.

Flow Characteristics

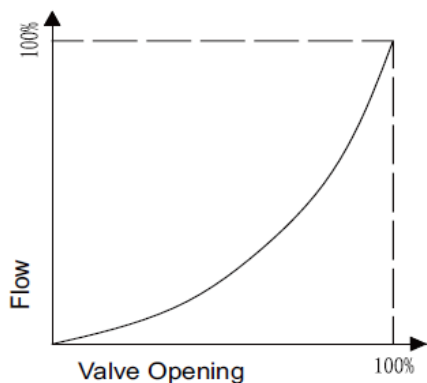

2-port water valve
3-port A-AB

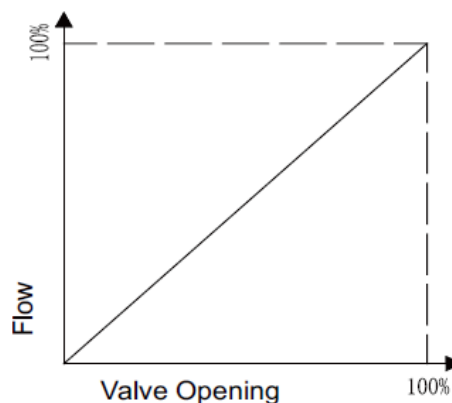

2-port steam valve/2-port
High-temp. steam valve
3-port B-AB

Relationship between Differential Pressure and Flow

$$Kvs = \frac{V}{\sqrt{\frac{\Delta P}{100}}}$$

ΔP : Differential pressure when valve is full open (Unit: KPa)

V: Rating flow at the ΔP (Unit: m³/h)

Kvs: Nominal flow coefficient, which refers to the flow when medium (Density = 1g/cm³) goes through the full open control valve, whose ΔP is 100KvPa.

Structure Characteristics

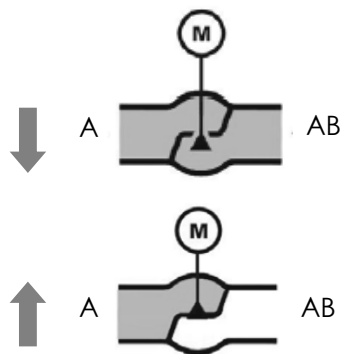
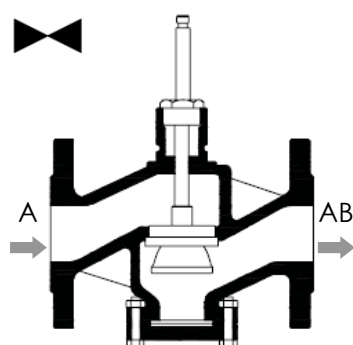

2-port Valve

When the valve stem is at lower limit, the valve will be opened.

When the valve stem is at upper limit, the valve will be closed.

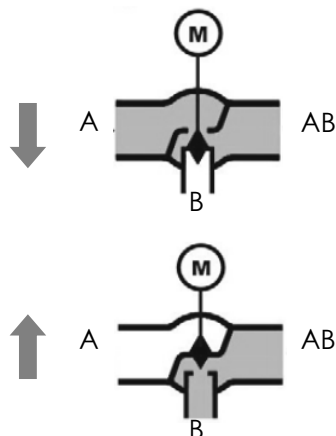
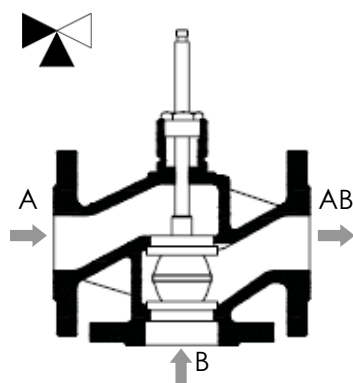

3-port Mixing Valve

When actuator stem is at lower limit, the valve will be opened from A to AB and closed from B to AB.

When actuator stem is at upper limit, the valve will be closed from A to AB and opened from B to AB.

Connection With Pipeline

1. The valve can be installed on the water supply or return pipeline, and it is recommended to install it on the return pipeline (installing it on the return pipeline can make water flow control more stable, and the temperature of the hot water return part is lower, which can extend the service life of the valve).
2. Filter and check valve are recommended to be installed.
3. When the medium is steam, install draw off valve in the pipe can remove the condensed water, or it will affect the service time of valve.
4. Please note that the medium flow direction in valve should be consistent with the medium of pipeline!

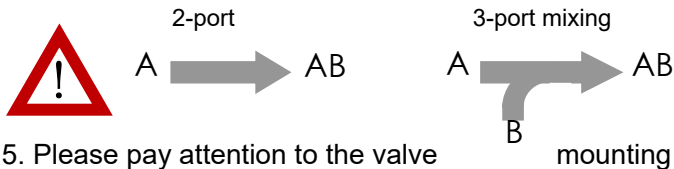

5. Please pay attention to the valve

mounting orientation!

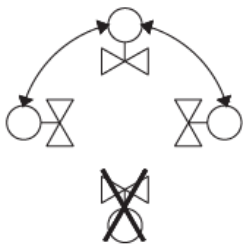

Medium is chilled/hot water
Downward installation is forbidden.

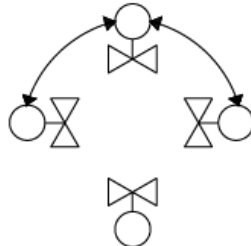

Medium is steam water
Any installation position is OK.

Combination with Actuator

You can complete the installation with the actuator's Allen wrench. It doesn't need further tools or any adjustment. The actuator has self-stroking function.

Warning! Prohibit installing outdoors to avoid PCB damage due to the condensation and water. Rain cover(TRAIN-1) and heating belt(THOT-3) are necessary in case of outdoor installation.

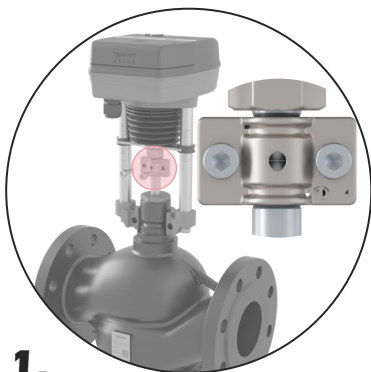

1.

Loosen the slider and clip, then put the actuator on the valve body and keep the two connecting faces coinciding, fix the screws on the slit with Allen wrench.

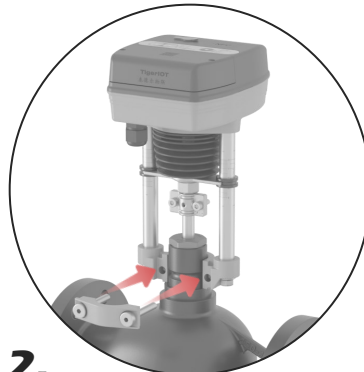

2.

Place the slot into the actuator and tighten the two screws.



3.

The assembly of the actuator and valve is completed.

Dimension(2-port)

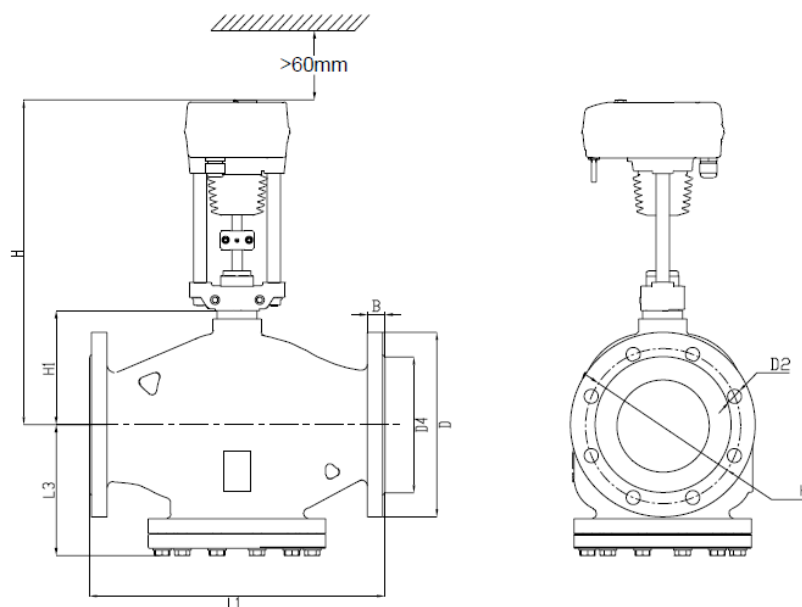

• PN16 Series Dimension

DN	B (mm)	D (mm)	D2 (mm)	D4 (mm)	K (mm)	L1 (mm)	L3 (mm)	H1 (mm)	N.W kg	H 1000N (mm)	H 3000N (mm)
DN65	20	185	4-19	118	145	290	104	70	15.5	345	355
DN80	22	200	8-19	132	160	310	120.5	77	20.5	352	365
DN100	23	220	8-19	156	180	350	135.5	93	29.6	/	378
DN125	24	250	8-19	184	210	400	155.5	118	39	/	403
DN150	25	285	8-23	211	240	480	170.5	138	55.1	/	423

• PN25 Series Dimension

DN	B (mm)	D (mm)	D2 (mm)	D4 (mm)	K (mm)	L1 (mm)	L3 (mm)	H1 (mm)	N.W kg	H 1000N (mm)	H 3000N (mm)
DN65	20	185	8-19	118	145	290	104	70	18	345	355
DN80	22	200	8-19	132	160	310	120.5	77	25	352	365
DN100	23	235	8-23	156	190	350	135.5	93	38	/	378
DN125	24	270	8-28	184	220	400	155.5	118	52	/	403
DN150	25	300	8-28	211	250	480	170.5	138	70.5	/	423

Remark: At least 60mm installation space should be reserved for the actuator.



Dimension(2-port)

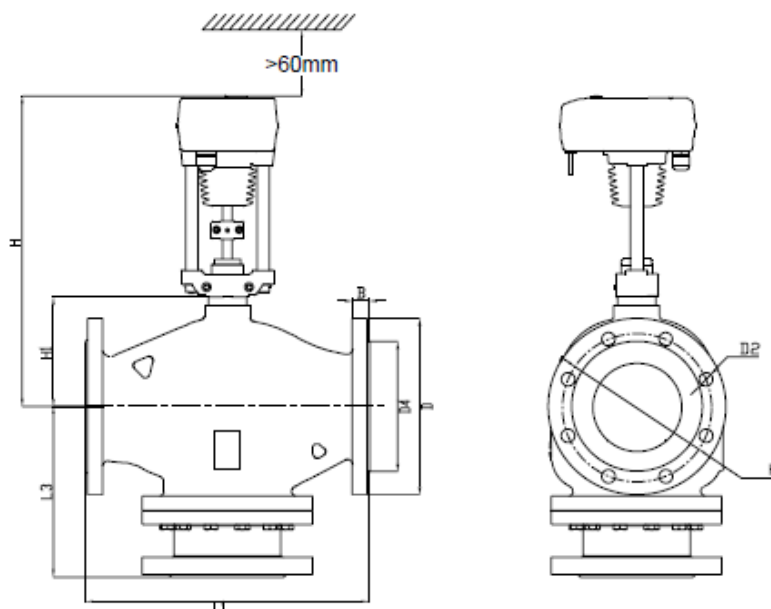

• PN16 Series Dimension

DN	B (mm)	D (mm)	D2 (mm)	D4 (mm)	K (mm)	L1 (mm)	L3 (mm)	H1 (mm)	N.W kg	H 1000N (mm)	H 3000N (mm)	H 5000N (mm)
DN65	20	185	4-19	118	145	290	145	70	18.3	345	355	/
DN80	22	200	8-19	132	160	310	170.5	77	24	352	365	/
DN100	23	220	8-19	156	180	350	184	93	33	/	378	/
DN125	24	250	8-19	184	210	400	212.5	118	44	/	403	423
DN150	25	285	8-23	211	240	480	243.5	138	60.7	/	423	443

• PN25 Series Dimension

DN	B (mm)	D (mm)	D2 (mm)	D4 (mm)	K (mm)	L1 (mm)	L3 (mm)	H1 (mm)	N.W kg	H 1000N (mm)	H 3000N (mm)	H 5000N (mm)
DN65	20	185	8-19	118	145	290	145	70	18.3	345	355	/
DN80	22	200	8-19	132	160	310	170.5	77	24	352	365	/
DN100	23	235	8-23	156	190	350	184	93	33	/	378	/
DN125	24	270	8-28	184	220	400	212.5	118	44	/	403	423
DN150	25	300	8-28	211	250	480	243.5	138	60.7	/	423	443

Remark: At least 60mm installation space should be reserved for the actuator.



Technical Parameters

• Functional data	
Nominal size	DN65-DN150
Nominal pressure	PN16 / PN25
Flow Characteristics	
2-port water valve	A-AB: equal-percentage
2-port steam valve	A-AB: equal-linear
3-port water valve/3-port steam valve	A-AB: equal-percentage, B-AB: equal-linear
Rangeability	>100: 1
Leakage rate	
2-port water valve/3-port water valve 2-port steam valve	A-AB: ≤0.01% kvS, B-AB: ≤0.02% kvs ≤0.001% kvs
Permissible Medium	
water valve (-25~150°C)	Cold/hot water, ionized water, ethylene glycol solution, industrial refrigerant
Steam Valve (2~180°C)	Saturated steam (< 0.69MPa)
High-temp. Steam Valve (2~250°C)	Overheated steam(≤250°C)
Connection Standard	Flanged connection ISO7005-2

• Spare parts materials	
Valve Body*	SS304
Valve Stem	Stainless Steel
Valve Core	Stainless Steel
Sealing Ring	PTFE

Remark: * The default material of the valve is 304 stainless steel, and 316, 316L, 2205 duplex steel, and 310S duplex steel can also be selected.

• Environmental condition	
Running	
Ambient temperature	-25~+65°C
Ambient humidity	≤95% RH
Storage	
Ambient temperature	-40~+65°C
Ambient humidity	≤95% RH

