



SPECIFICATIONS

DN mm	DN25 - DN300
DN inch	1" - 12"
Liner	EPDM, NBR
Temperature	EPDM -10°C to 100°C, NBR -10°C to 80°C
Type of body	Lug, Wafer
Application	EPDM : Hot water, Cold water, HVAC, Irrigation NBR : Hydrocarbons, Waste water, Sea water, Fuel, Natural gas, Oil, Grease, Compressed air, Glycol
Flange	PN10, PN10/16, PN16 (JIS 10K + ANSI - ASA 150 for wafer body)
Valve Standard	EN 593
Face to face	EN 558-1 series 20, ISO 5752 series 20, API 609 table 2
Shell tightness test	According to EN 12266-1 resistance and tightness of the body : test P11 (1,5 x allowable operating pressure)
Seat tightness test	According to EN 12266-1 seat tightness : test P12 rate A (1,1 x allowable operating pressure)
Top flange	EN ISO 5211
Options	Other specifications on request

ADVANTAGES

1. Omeax Z300 butterfly guarantee perfect tightness thanks to precise machining of disc and shaft.
2. 1 Piece shaft and spline driven disc design assure accurate torque transmission.
3. The spherical disc machining allows the disc to have equal penetration into the liner.
4. Environmental friendly design thanks to tongue and groove design (dove tail) replacable liner.
5. Extended neck for insulation - no fabricated extensions required.

DIMENSIONS

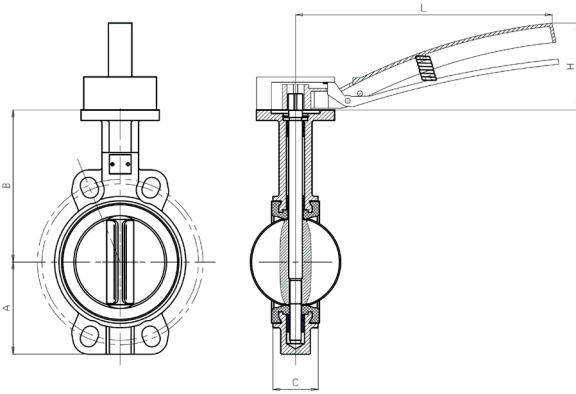

DN mm	DN inch	PFA	A	B	C	L	H
25	1"	11	62	115	32	200	20
32	1 1/4"	11	62	115	32	200	20
40	1 1/2"	14	72	120	32	200	20
50	2"	16	72	126	43	200	80
65	2 1/2"	16	78	141	46	200	80
80	3"	16	90	146	46	200	80
100	4"	16	102	166	52	290	100
125	5"	16	120	181	56	290	100
150	6"	16	146	187	56	290	100
200	8"	16	165	227	62	450	130
250	10"	16	197	260	68	450	130
300	12"	16	232	305	78	450	130

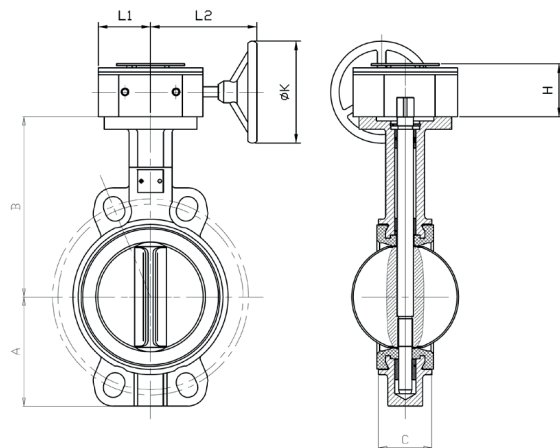

DN mm	DN inch	PFA	A	B	C	L1	L2	ØK	H
50	2"	16	72	126	43	53	148	150	75
65	2 1/2"	16	78	141	46	53	148	150	75
80	3"	16	90	146	46	53	148	150	75
100	4"	16	102	166	52	53	148	190	75
125	5"	16	120	181	56	53	148	190	75
150	6"	16	146	187	56	53	148	190	75
200	8"	16	165	227	62	73	190	290	76
250	10"	16	197	260	68	73	190	290	76
300	12"	16	232	305	78	80	225	290	82

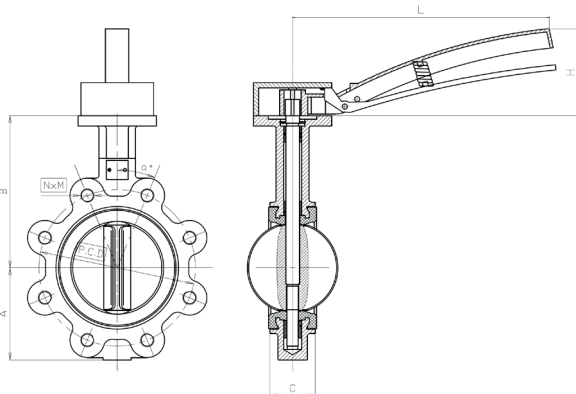

DN mm	DN inch	PFA	A	B	C	P.C.D	N x M	A°	L	H
25	1"	11	62	115	32	85	4 X M12	45°	200	20
32	1 1/4"	11	62	115	32	100	4 X M16	45°	200	20
40	1 1/2"	14	72	120	32	110	4 X M16	45°	200	20
50	2"	16	72	126	43	125	4 X M16	45°	200	80
65	2 1/2"	16	78	141	46	145	4 X M16	45°	200	80
80	3"	16	90	146	46	160	8 X M16	22.5°	200	80
100	4"	16	102	166	52	180	8 X M16	22.5°	290	100
125	5"	16	120	181	56	210	8 X M16	22.5°	290	100
150	6"	16	146	187	56	240	8 X M20	22.5°	290	100
200	8"	16	165	227	62	295	12 X M20	15°	450	130
250	10"	16	197	260	68	355	12 X M24	15°	450	130
300	12"	16	232	305	78	410	12 X M24	15°	450	130
200	8"	10	165	227	62	295	8 X M20	22.5°	450	130
250	10"	10	197	260	68	350	12 X M20	15°	450	130
300	12"	10	232	305	78	400	12 X M20	15°	450	130

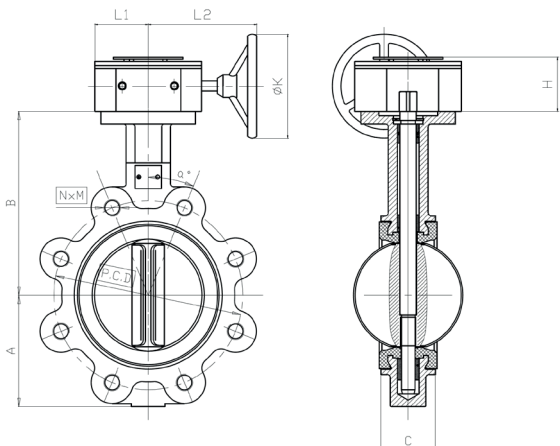

DN mm	DN inch	PFA	A	B	C	P.C.D	N x M	A°	L1	L2	ØK	H
50	2"	16	72	126	43	125	4 X M16	45°	53	148	150	75
65	2 1/2"	16	78	141	46	145	4 X M16	45°	53	148	150	75
80	3"	16	90	146	46	160	8 X M16	22.5°	53	148	150	75
100	4"	16	102	166	52	180	8 X M16	22.5°	53	148	190	75
125	5"	16	120	181	56	210	8 X M16	22.5°	53	148	190	75
150	6"	16	146	187	56	240	8 X M20	22.5°	53	148	190	75
200	8"	16	165	227	62	295	12 X M20	15°	73	190	290	76
250	10"	16	197	260	68	355	12 X M24	15°	73	190	290	76
300	12"	16	232	305	78	410	12 X M24	15°	80	225	290	82
200	8"	10	165	227	62	295	8 X M20	22.5°	73	190	290	76
250	10"	10	197	260	68	350	12 X M20	15°	73	190	290	76
300	12"	10	232	305	78	400	12 X M20	15°	80	225	290	82



Omeax SARL

contact@omeax.com - <http://www.omeax.com>

Omeax is not responsible for any possible errors in catalogue, brochures and on website. This datasheet is subject to change without notice. All right reserved.

December 2024
Page 2

DIMENSIONS

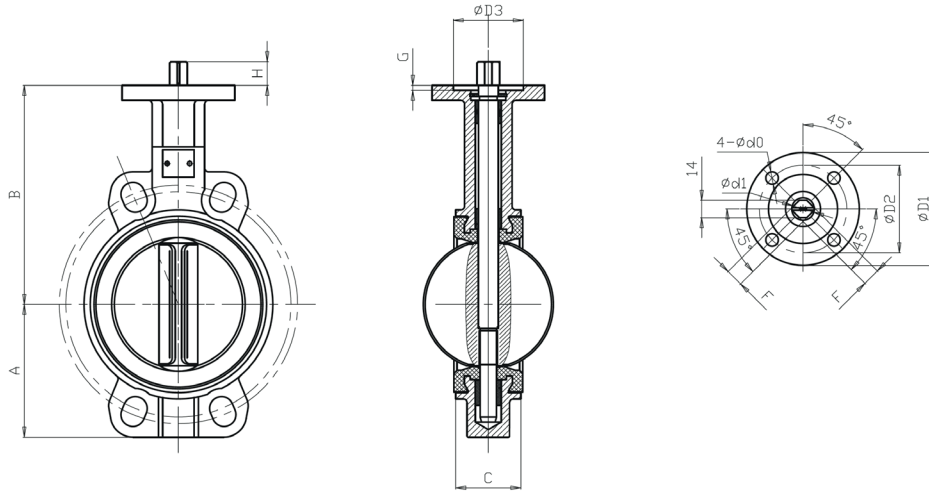

DN mm	DN inch	PFA	A	B	C	ØD1	ØD2	ØD3	4-Ød0	Ød1	F x F	K	G	H
25	1"	11	62	115	32	65	50	35 ^{+0.45} / _{+0.25}	7 - Ø0.76	12.6	11 X 11	11	4	20
32	1 1/4"	11	62	115	32	65	50	35 ^{+0.45} / _{+0.25}	7 - Ø0.76	12.6	11 X 11	11	4	20
40	1 1/2"	14	72	120	32	65	50	35 ^{+0.45} / _{+0.25}	7 - Ø0.76	12.6	11 X 11	11	4	20
50	2"	16	72	126	43	65	50	36	4 - Ød6.5	13	11 X 11	11	4	16
65	2 1/2"	16	78	141	46	65	50	36	4 - Ød6.5	13	11 X 11	11	4	16
80	3"	16	90	146	46	65	50	36	4 - Ød6.5	13	11 X 11	11	4	16
100	4"	16	102	166	52	90	70	56	4 - Ød8.5	17	14 X 14	14	4	19
125	5"	16	120	181	56	90	70	56	4 - Ød8.5	17	14 X 14	14	4	19
150	6"	16	146	187	56	90	70	56	4 - Ød8.5	17	14 X 14	14	4	19
200	8"	16	165	227	62	125	102	71	4 - Ød10.5	22	17 X 17	20	4	24
250	10"	16	197	260	68	125	102	71	4 - Ød10.5	28	22 X 22	26	4	24
300	12"	16	232	305	78	125	102	71	4 - Ød10.5	28	22 X 22	26	4	24

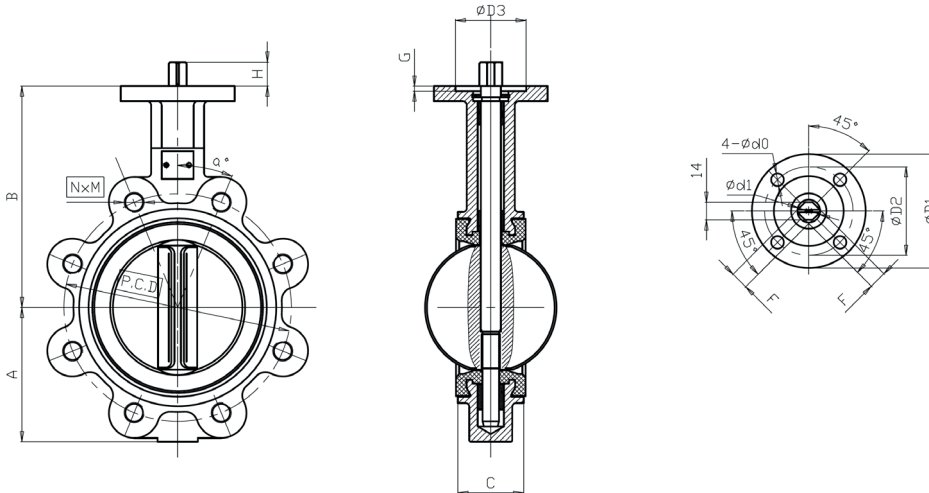

DN mm	DN inch	PFA	A	B	C	P.C.D	N x M	A°	ØD1	ØD2	ØD3	4-Ød0	Ød1	F x F	K	G	H
25	1"	11	62	115	32	85	4 X Ø14	45°	65	50	35.25	4 X Ø7	13	11 X 11	11	4	20
32	1 1/4"	11	62	115	32	100	4 X Ø19	45°	65	50	35.25	4 X Ø7	13	11 X 11	11	4	20
40	1 1/2"	14	72	120	32	110	4 X Ø14	45°	65	50	35.25	4 X Ø7	13	11 X 11	11	4	20
50	2"	16	72	126	43	125	4 X M16	45°	65	50	36	4 - Ød6.5	13	11 X 11	11	4	16
65	2 1/2"	16	78	141	46	145	4 X M16	45°	65	50	36	4 - Ød6.5	13	11 X 11	11	4	16
80	3"	16	90	146	46	160	8 X M16	22.5°	65	50	36	4 - Ød6.5	13	11 X 11	11	4	16
100	4"	16	102	166	52	180	8 X M16	22.5°	90	70	56	4 - Ød8.5	17	14 X 14	14	4	19
125	5"	16	120	181	56	210	8 X M16	22.5°	90	70	56	4 - Ød8.5	17	14 X 14	14	4	19
150	6"	16	146	187	56	240	8 X M20	22.5°	90	70	56	4 - Ød8.5	17	14 X 14	14	4	19
200	8"	16	165	227	62	295	12 X M20	15°	125	102	71	4 - Ød10.5	22	17 X 17	20	4	24
250	10"	16	197	260	68	355	12 X M24	15°	125	102	71	4 - Ød10.5	28	22 X 22	26	4	24
300	12"	16	232	305	78	410	12 X M24	15°	125	102	71	4 - Ød10.5	28	22 X 22	26	4	24
200	8"	10	165	227	62	295	8 X M20	22.5°	125	102	71	4 - Ød10.5	22	17 X 17	20	4	24
250	10"	10	197	260	68	350	12 X M20	15°	125	102	71	4 - Ød10.5	28	22 X 22	26	4	24
300	12"	10	232	305	78	400	12 X M20	15°	125	102	71	4 - Ød10.5	28	22 X 22	26	4	24



Omeax SARRL

contact@omeax.com - http://www.omeax.com

Omeax is not responsible for any possible errors in catalogue, brochures and on website. This datasheet is subject to change without notice. All right reserved.

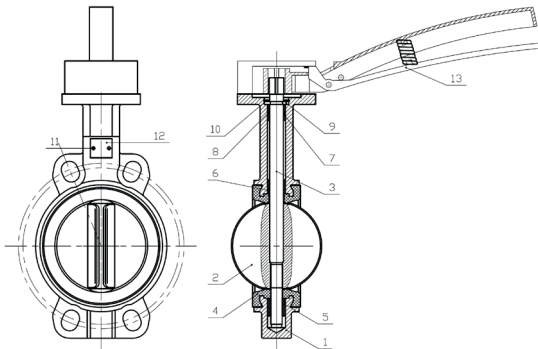

Designation	Materials
1.Body	Ductile iron, cast iron
2.Disc	Stainless steel 316, ductile iron
3.Stem	Stainless steel 416
4.Seat	EPDM, NBR
5.Down bushing	Aluminium-bronze
6.Long bushing	Aluminium-bronze
7.Short bushing	Aluminium-bronze
8.O-ring	EPDM, NBR
9.Bisect-ring	Stainless steel
10.Retainer-ring	Carbon steel
11.Plate rivet	Aluminium
12.Name plate	Aluminium
13.Handle	Ductile iron

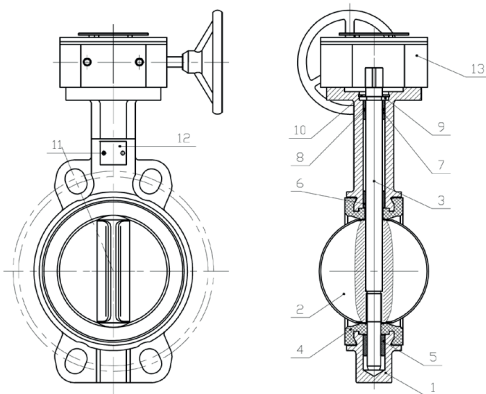

Designation	Materials
1.Body	Ductile iron, cast iron
2.Disc	Stainless steel 316, ductile iron
3.Stem	Stainless steel 416
4.Seat	EPDM, NBR
5.Down bushing	Aluminium-bronze
6.Long bushing	Aluminium-bronze
7.Short bushing	Aluminium-bronze
8.O-ring	EPDM, NBR
9.Bisect-ring	Stainless steel
10.Retainer-ring	Carbon steel
11.Plate rivet	Aluminium
12.Name plate	Aluminium
13.Gearbox	Ductile iron

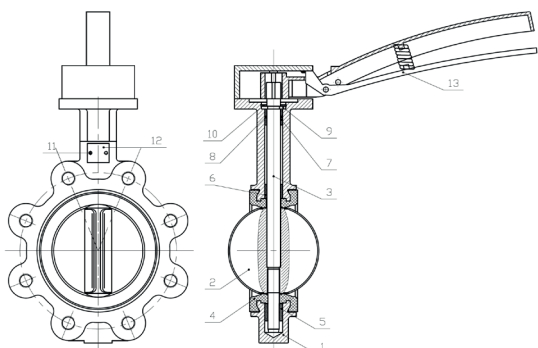

Designation	Materials
1.Body	Ductile iron, cast iron
2.Disc	Stainless steel 316, ductile iron
3.Stem	Stainless steel 416
4.Seat	EPDM, NBR
5.Down bushing	Aluminum-bronze
6.Long bushing	Aluminum-bronze
7.Short bushing	Aluminum-bronze
8.O-ring	EPDM, NBR
9.Bisect-ring	Stainless steel
10.Retainer-ring	Carbon steel
11.Plate rivet	Aluminium
12.Name plate	Aluminium
13.Handle	Ductile iron

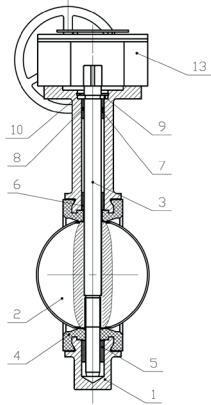
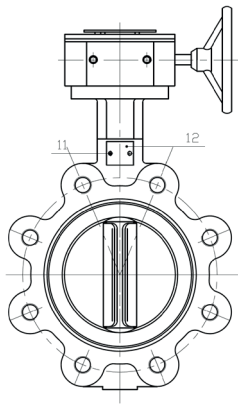

Designation	Materials
1.Body	Ductile iron, cast iron
2.Disc	Stainless steel 316, ductile iron
3.Stem	Stainless steel 416
4.Seat	EPDM, NBR
5.Down bushing	Aluminum-bronze
6.Long bushing	Aluminum-bronze
7.Short bushing	Aluminum-bronze
8.O-ring	EPDM, NBR
9.Bisect-ring	Stainless steel
10.Retainer-ring	Carbon steel
11.Plate rivet	Aluminium
12.Name plate	Aluminium
13.Gearbox	Ductile iron

Designation	Materials
1.Body	Ductile iron, cast iron
2.Disc	Stainless steel 316, ductile iron
3.Stem	Stainless steel 416
4.Seat	EPDM, NBR
5.Down bushing	Aluminum-bronze
6.Long bushing	Aluminum-bronze
7.Short bushing	Aluminum-bronze
8.O-ring	EPDM, NBR
9.Bisect-ring	Stainless steel
10.Retainer-ring	Carbon steel
11.Plate rivet	Aluminium
12.Name plate	Aluminium

Designation	Materials
1.Body	Ductile iron, cast iron
2.Disc	Stainless steel 316, ductile iron
3.Stem	Stainless steel 416
4.Seat	EPDM, NBR
5.Down bushing	Aluminum-bronze
6.Long bushing	Aluminum-bronze
7.Short bushing	Aluminum-bronze
8.O-ring	EPDM, NBR
9.Bisect-ring	Stainless steel
10.Retainer-ring	Carbon steel
11.Plate rivet	Aluminium
12.Name plate	Aluminium

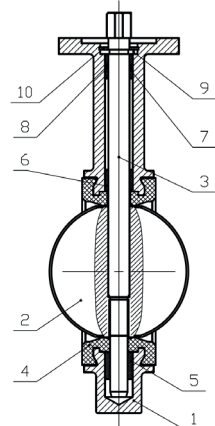
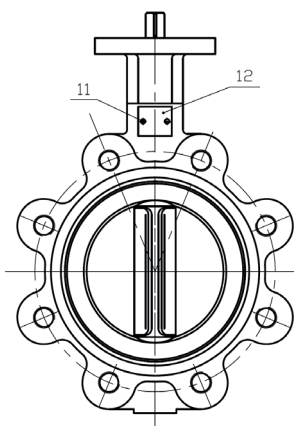
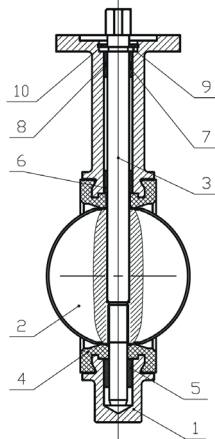
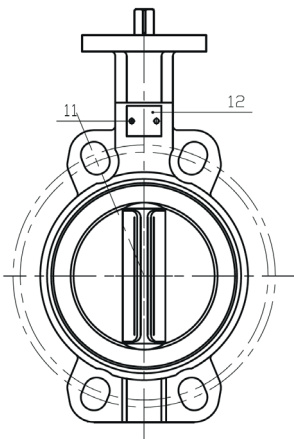

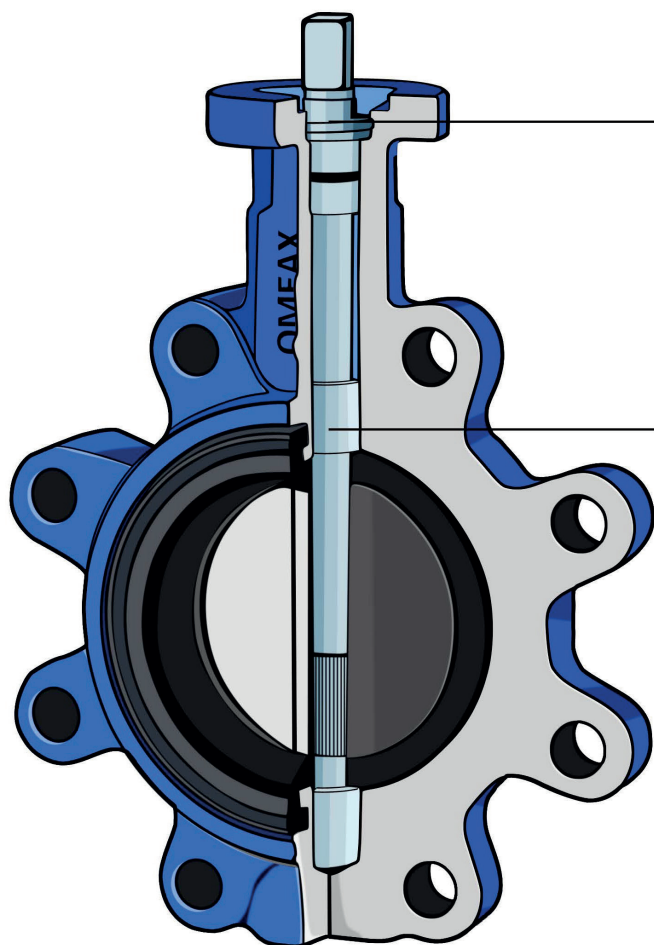

Perfect tightness

- Equipped with an anti-blowout circlip to maintain the shaft in his safe position and allow easy maintenance
- Double watertightness design allow a perfect tightness

Energy saving

- One piece shaft
- Spline driven disc and shaft
- Floating disc
- Better torque transmission to save energy and optimize electric or pneumatic actuator selection

TORQUE TABLE

Torque are given in N.m for EPDM liner with water at 25°C.
Safety factor not include.

DN mm	DN inch	PFA 16	PFA 10	PFA 6	PFA 3
25	1"	11	11	11	11
32	1"1/4	11	11	11	11
40	1"1/2	14	14	14	14
50	2"	10	8	6	6
65	2"1/2	12	10	8	8
80	3"	15	12	10	10
100	4"	31	20	15	10
125	5"	68	45	25	20
150	6"	100	80	75	60
200	8"	150	120	100	90
250	10"	240	180	140	110
300	12"	400	350	305	210

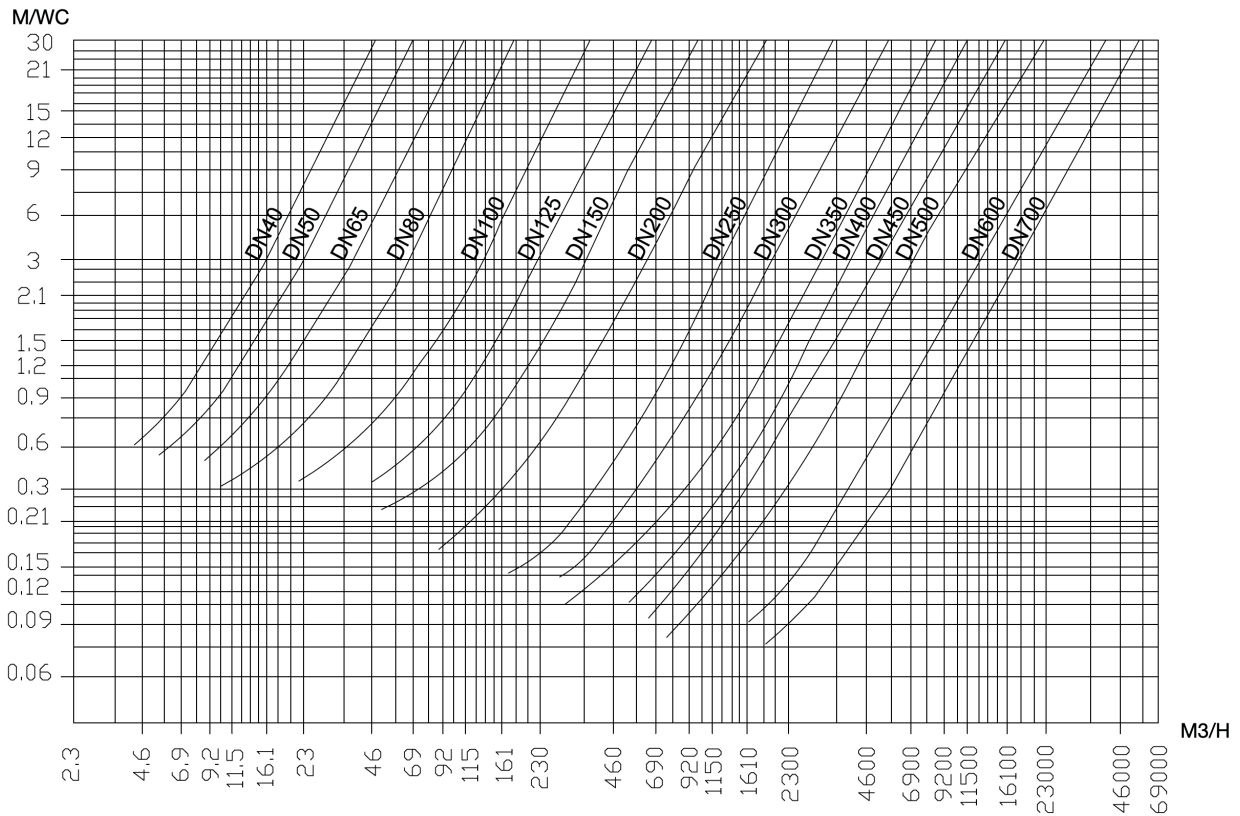

FLOW COEFFICIENT Cv

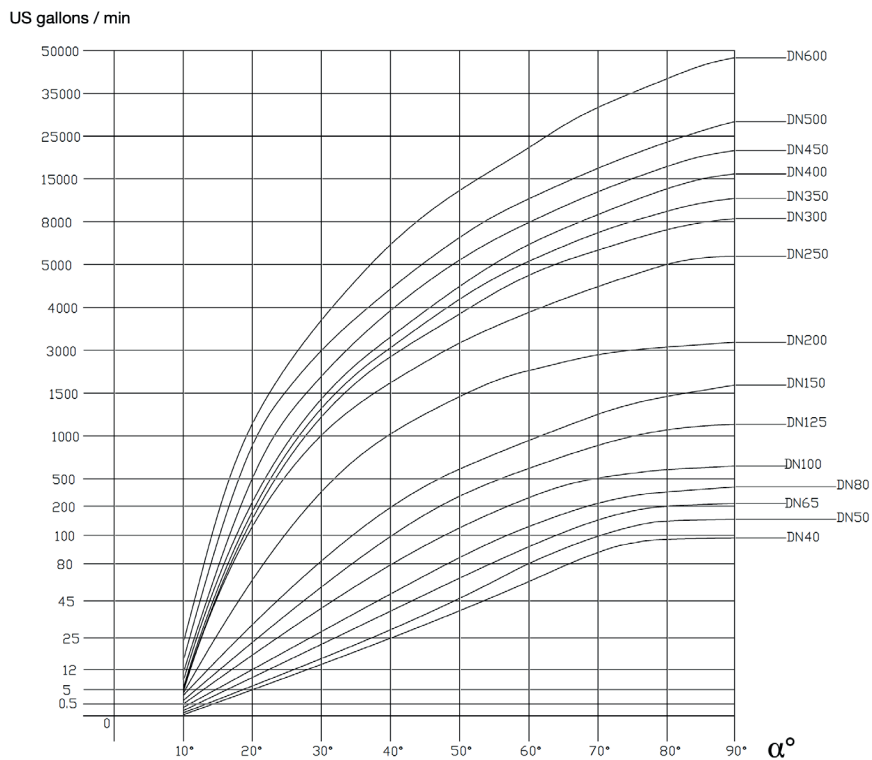

$$K_v = 0,865 \times C_v$$

